



© 2013 Intel Corporation

**Intel Open Source Graphics Programmer's Reference
Manual (PRM) for the 2013 Intel® Core™ Processor
Family, including Intel HD Graphics, Intel Iris™
Graphics and Intel Iris Pro Graphics**

Volume 8: Media VDBOX (Haswell)



Copyright

INFORMATION IN THIS DOCUMENT IS PROVIDED IN CONNECTION WITH INTEL® PRODUCTS. NO LICENSE, EXPRESS OR IMPLIED, BY ESTOPPEL OR OTHERWISE, TO ANY INTELLECTUAL PROPERTY RIGHTS IS GRANTED BY THIS DOCUMENT. EXCEPT AS PROVIDED IN INTEL'S TERMS AND CONDITIONS OF SALE FOR SUCH PRODUCTS, INTEL ASSUMES NO LIABILITY WHATSOEVER AND INTEL DISCLAIMS ANY EXPRESS OR IMPLIED WARRANTY, RELATING TO SALE AND/OR USE OF INTEL PRODUCTS INCLUDING LIABILITY OR WARRANTIES RELATING TO FITNESS FOR A PARTICULAR PURPOSE, MERCHANTABILITY, OR INFRINGEMENT OF ANY PATENT, COPYRIGHT OR OTHER INTELLECTUAL PROPERTY RIGHT.

A "Mission Critical Application" is any application in which failure of the Intel Product could result, directly or indirectly, in personal injury or death. SHOULD YOU PURCHASE OR USE INTEL'S PRODUCTS FOR ANY SUCH MISSION CRITICAL APPLICATION, YOU SHALL INDEMNIFY AND HOLD INTEL AND ITS SUBSIDIARIES, SUBCONTRACTORS AND AFFILIATES, AND THE DIRECTORS, OFFICERS, AND EMPLOYEES OF EACH, HARMLESS AGAINST ALL CLAIMS COSTS, DAMAGES, AND EXPENSES AND REASONABLE ATTORNEYS' FEES ARISING OUT OF, DIRECTLY OR INDIRECTLY, ANY CLAIM OF PRODUCT LIABILITY, PERSONAL INJURY, OR DEATH ARISING IN ANY WAY OUT OF SUCH MISSION CRITICAL APPLICATION, WHETHER OR NOT INTEL OR ITS SUBCONTRACTOR WAS NEGLIGENT IN THE DESIGN, MANUFACTURE, OR WARNING OF THE INTEL PRODUCT OR ANY OF ITS PARTS.

Intel may make changes to specifications and product descriptions at any time, without notice. Designers must not rely on the absence or characteristics of any features or instructions marked "reserved" or "undefined". Intel reserves these for future definition and shall have no responsibility whatsoever for conflicts or incompatibilities arising from future changes to them. The information here is subject to change without notice. Do not finalize a design with this information.

The products described in this document may contain design defects or errors known as errata which may cause the product to deviate from published specifications. Current characterized errata are available on request.

Implementations of the I2C bus/protocol may require licenses from various entities, including Philips Electronics N.V. and North American Philips Corporation.

Intel and the Intel logo are trademarks of Intel Corporation in the U.S. and other countries.

*Other names and brands may be claimed as the property of others.

Copyright © 2013, Intel Corporation. All rights reserved.



VDBOX Command Memory Interface

Table of Contents

VDBOX Command Memory Interface	3
VDBOX Registers	5
Scratch Bits.....	5
MFX Architecture	6
MFX Introduction	6
MFC Overview.....	7
Example Usage Model.....	8
Sample Algorithmic Flow	10
Synchronization Mechanism.....	12
Restrictions.....	14
MFD Overview	15
MFD Memory Interface	20
MFD Codec-Specific Commands.....	21
MFX Interruptability Model.....	22
Decoder Input Bitstream Formats	23
AVC Bitstream Formats – DXVA Short	23
AVC Bitstream Formats – DXVA Long.....	23
VC1 Bitstream Formats – Intel Long	23
MPEG2 Bitstream Formats – DXVA1.....	23
JPEG Bitstream Formats – Intel	23
Concurrent, Multiple Video Stream Decoding Support.....	24
MFX Codec Commands Summary	25
MFX Decoder Commands Sequence.....	31
Examples for AVC	32
Examples for VC1.....	34
Examples for JPEG	35
Examples of SVC Command Sequences.....	36
MFX Pipe Common Commands	42
Bitplane Buffer.....	45
Video Codecs	46



AVC (H.264)	47
AVC Common Commands	47
AVC Decoder Commands	48
AVC Encoder PAK Commands	60
MPEG-2	114
MPEG2 Decoder Commands	115
MPEG2 Encoder PAK Commands	116
JPEG and MJPEG	129
More Decoder and Encoder	134
MFX Deblocking Commands	157
Encoder StreamOut Mode Data Structure Definition	158
PAK Multi-Pass	160
Driver Usage	161
Programming Reference	162
Monochrome Picture Processing	162
Context Switch	163
Pipeline Flush	164
MMIO Interface	165
Decoder Registers	167
Encoder Registers	168
Row Store Sizes and Allocations	169



VDBOX Registers

This section describes the VDBOX Command Memory Interface registers.

Scratch Bits

GAC_MODE - Mode Register for GAC



MFX Architecture

This section and the following sections of Media VDBOX contain the referential documentation on the Multi-Format Codecs, or MFX for those series of chips starting with Ivy Bridge.

MFX Introduction

Multi-Format Codec (MFX) Engine is the hardware fixed function pipeline for decode and encoding. It includes multi-format decoding (MFD) and multi-format encoding (MFC).

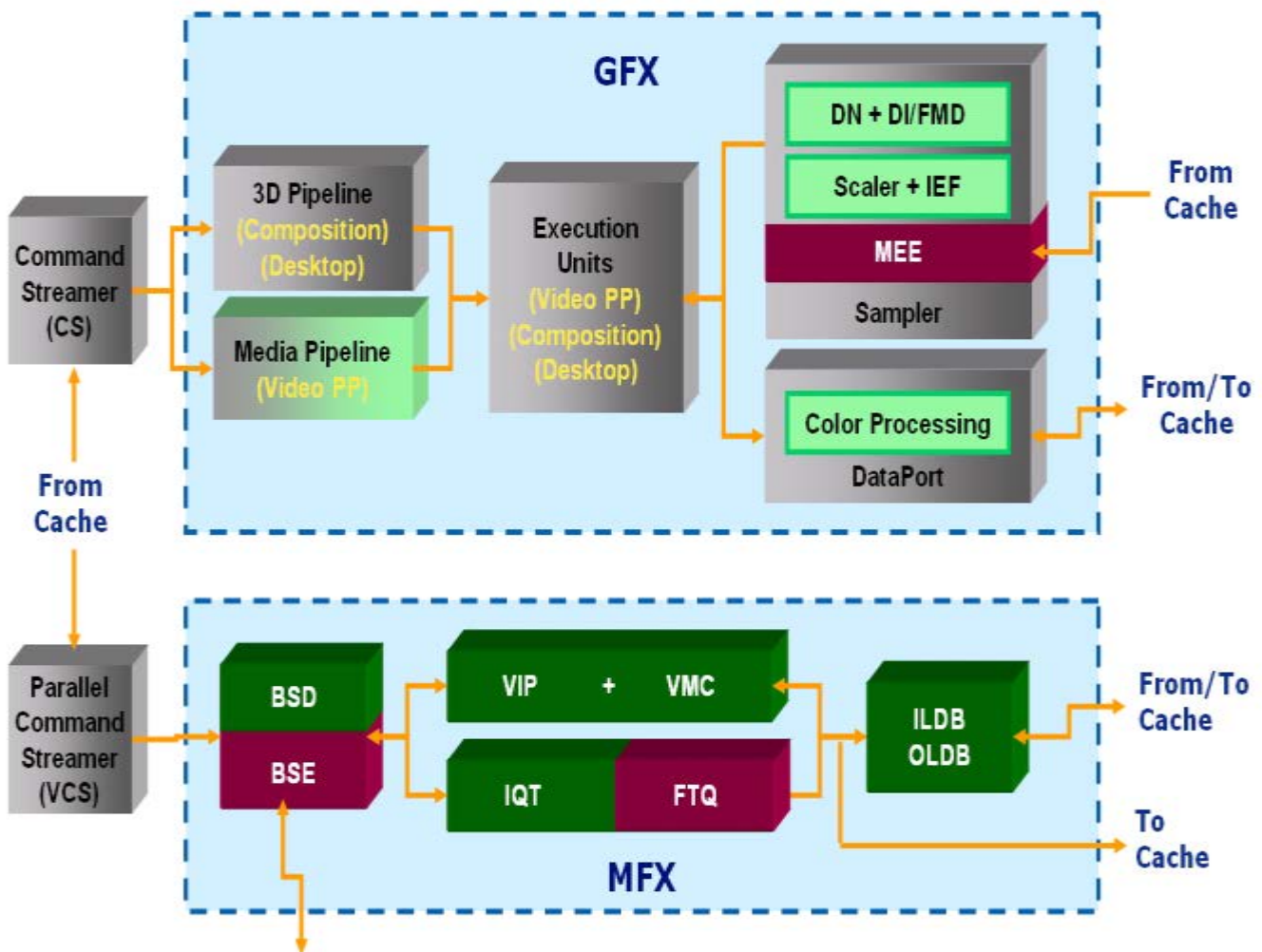



MFC Overview

Multi-Format Codec (MFX) Engine is the hardware fixed function pipeline for decode and encoding. It includes multi-format decoding (MFD) and multi-format encoding (MFC).

Many decoding function blocks in MFD such as VIP, VMC, IQT, etc, are also used in encoding mode. Two blocks, FTQ and BSE, are encoding only.

The encoding process is partitioned across host software, the GPE engine, and the MFX engine. The generation of transport layer, sequence layer, picture layer, and slice header layer must be done in the host software. GP hardware is responsible for compressing from Slice Data Layer down to all macro-block and block layers. Specifically, GPE w/ VME acceleration is for motion vector estimation, motion estimation, and code decision. The **VME**(*Video Motion Estimation*) is located next to all image processing units, such as DN (*denoise*) and DI (*deinterlace*) in sampler in GPE. MFX is for final bit packing and reconstructed picture generation.

MFC is operated concurrently with and independently from the GPE (3D/Media) pipeline with a separate command streamer. The two parallel engines have similar command protocol. They can be executed in parallel with different context. For encoding, motion search, MB mode decision, and rate control are performed using GPE pipeline resources.

MFC is implemented to achieve the following objectives:

- Compliant with next generation high definition optical video disc requirements, with sufficient performance headroom:
 - Support AVC 4:2:0 Main Profile and High Profile only (8-bit only), up to Level 4.1 resolution and up to 40 mbps bitstream. With sufficient duty cycles, higher bit rate contents can also be encoded. There is no support for Baseline, Extended, or High-10 Profiles.
- Performance requirements with MFX core frequency above 667MHz:
 - Real-time performance with 20% duty cycle or less.
 - Support concurrent decoding of two active HD bitstreams of different formats (for example, one AVC and one VC1 HD bitstream) and one active HD encoding.

As the result of this hardware partitioning, VPP and ENC are always running in GPE, and PAK is what runs exactly in MFC.

PAK – residue packing and entropy coding, including block transformation, quantization, data prediction, bitrate tuning and reference decoding. It delivers final packed bitstream and decoded key-frame reference:

- As the same as ENC, PAK is invoked on a Slice boundary; a single call of VPP can lead to multiple calls for PAK.
- Rate control is inside ENC and PAK only, not in VPP.
- PAK must always perform with reconstructed reference picture.



There is a general dependency of the three operation pipelines. Semaphores are inserted either according to frames or slices. The main CS will also be notified when the decoded reference is ready for the next frame set to be encoded. The detailed discussion will be found in a later section.

Host software is responsible for encoding the transport stream and all the sequence, picture, and slice layer/header in the bit-stream; the MFC system is responsible for compressing from Slice Data Layer down to all macro-block and block layers.

Example Usage Model

Encoding flow described here assumes that input stream is a series of uncompressed video frames that will be converted into YUV (4:2:0) for encoding. Depending upon how this stream is derived, application usage may be listed as below:

- Single video stream encoder, video capture+encode, home movie making (SD/HD)
- PVR usage: Decode the incoming stream to generate YUV (uncompressed) frames and then encode to have a compressed file size storage (also transcoding)
- The HW asset needs to support single stream decode (SD+HD) and independent stream encode (HD). This usage can be enabled by scheduling HW decoder at command stream level instead of HW managed time-slicing.

For illustration purpose only, here are two possible usage modes: *user-friendly mode* and *professional mode*.

- **Professional mode (PFM):**
Application does the picture order sequencing and submit the picture frame-by-frame to VPP as IN coded order with specified frame coding type, and it has the full custom control of the GOP structure
 - no restriction on numbers of I, P and B
 - no restriction on individual interlace and progressive picture
- **User-friendly mode (UFM):**
Application presents video in display order. In this case, the application can only specify two pre-defined parameters: **NumP** and **NumB**, for the underlining pre-defined GOP structure.
 - Where **NumP** is the number of P (or P/P) -frames in a GOP, and **NumB** is the number of B (or B/B) frames between two consecutive key (I, P, I/I, I/P, or P/P) frames.

In this case, the driver will need to composite the final GOP structure based on the application parameters, and need to perform the proper sequencing of picture to the VPP in the coding order (i.e. it will hold the pictures in the memory and submit the correct picture buffer address only in coding order), then pass the data in as the same as in PFM.

A GOP (group of pictures) is a complete encoding unit consisting of a number of video frames. In general a GOP structure has the following form:

I0, B-B1, K1, B-B2, K2, B-B3, K3, ... , B-BN, KN



in display order, or equivalently

I-0, K1, B-B1, K2, B-B2, K3, B-B3, ... , KN, B-BN

in coded storage/transmission order. Where K is a key (i.e. I or P) frame, and B-Bi is a set of Mi consecutive B frames. Thus, there are $1+N+(M1+...+MN)$ frames in a GOP.

In the UFM, we have $N = \text{NumP}$, and $M_k = \text{NumB}$ for all k. Where NumB must be an number from 0, 1, 2, or 3. For examples:

- NumP = 5, NumB = 2: GOP = I0 P3 B1 B2 P6 B4 B5 P9 B7 B8 P12 B10 B11 P15 B13 B14 I16 ...
- NumP = 7, NumB = 0: GOP = I0 P1 P2 P3 P4 P5 P6 P7 I8 P9 ...
- NumP = 0, NumB = 0: GOP = I0 I1 I2 I3 I4 I5 I6 I7 I8 I9 ...

As a result, a unified hardware interface is given.

All frame/slice type determination/specifications are performed prior to the hardware interface in coded order.



Sample Algorithmic Flow

Assuming all the hardware components are given, there are infinite usage possibilities left with intention for software to decide according to its own application needs depending upon the balanced requirement of coding speed, frame latency, power-consumption, and video quality, and depending upon the usage modes and user preferences (such as low-frame-rate-high-frame-quality vs. high-frame-rate-low-frame-quality).

The last part of this chapter, we illustrate a generic sample to show how a compression algorithm can be implemented to use our hardware.

Step 1. Application or driver initializes the encoder with desired configuration, including speed, quality, targeted bit-rate, input video info, and output format and restrictions.

Step 2. VPP – Application or driver feeds VPP one frame at a time in coded order with specified frame or field type, as well as transcoding informations: motion vectors, coded complexity (i.e. bit size). It will perform denoising and deblocking based on original and targeted bit-rate, and output additional 4 spatial variances and 2 temporal variances for each macroblock as well as the whole frame.

Step 3. ENC – Application or driver feeds ENC one coding slice buffer at a time including all VPP output. The frame level data is accessible to all slices.

- a. Encoding setup unit (**ESE**) will set picture level quality parameters (including LUTs, and other costing functions) and set target bit-budget (TBB) and maximal bit-budget (MBB) to each macroblock based on rate-control (**RC**) scheme implemented. For B-frames, it will also make ME searching mode decision (either Fast, Slow or Uni-directional).
- b. Loop over all macroblocks: calculate searching center (**MVP**) perform individual ME and IE (**MEE**). Multi-thread may be designed for HW according to a zigzag order for minimal dependency issue.
- c. ENC make microblock level code decision (**CD**) outputs macroblock type, intra-mode, motion-vectors, distortions, as well as TBBs and MBBs.

Step 4. PAK – Application or driver feeds PAK one array of coded macroblocks covering a slice at a time, including all ENC output. Original frame buffer and reconstructed reference frame buffers are also available for PAK to access.

- a. PAK may create bitstreams for all sequence, gop, picture, and slice level headers prior the first macroblock.
- b. Loop over all macroblocks, accurate prediction block is constructed for either inter- or intra- predictions (**VMC & VIP**). If MB distortion is less than some predetermined threshold, for a B slice this step can be skipped as well as the Steps (c)-(e) and jump directly to Step (f); for a key slice the prediction calculated here will be directly used as the reference thus it jumps to Step (e) after this step.
- c. Differencing the predicted block from the original block derives the residue block. Forward transformation and quantization (**FTQ**) is performed. For B slice, it will jump to



- Step (f) right after. For other types of slice, Steps (d) and (e) can be performed in a thread in parallel with Step (f) and beyond.
- d. This is for accurate construction of reference pictures. Inverse quantization and inverse transformation (**IQT**) are performed and added to the predictions to have the decoded blocks.
 - e. **ILDB** is applied accordingly to the reconstructed blocks.
 - f. Meanwhile macroblock codes: including its configuration info (types and modes), motion info (motion vectors and reference ids), and residual info (quantized coefficients), are collected for packing (**BSE**) in the following sub-steps:
 - i. Code clean-up (in **MPR**). Check and verify Mbtype and Cbps, use Skip or Zero respectively if one can. In principal, when there are equivalent codes, use the simple one.
 - ii. Drop dependency (in **MPR**). Calculate relative codes from the absolute codes by associate thm with neighborhood information. All neighborhood correlations are solved in this step.
 - iii. Unify symbols (in **SEC**). Translate relative codes into symbols, and table or context indices that are independent of the concept of syntax type.
 - iv. Entropy coding (**VLE**) on symbols.
 - g. Parsing bitstream data in RBSP form (in **VLE**), and output to application or driver.
 - h. By the end of each picture, write out the accurate actual data size to designate buffer for ENC to access.



Synchronization Mechanism

Encoding of a video stream can be broken down to three major steps (as explained in the previous section):

1. VPP: video-stream pre-processing.
2. ENC: encoding, *i.e.* code decision of inter-MVs and intra-modes. And
3. PAK: bit-stream packing,
 - a) residual calculation, transformation, and quantization,
 - b) code bit-stream packing, and
 - c) reference generation of keyframes.

This section describes an architectural solution to map the first two steps in the GFX engine and the last step in the MFX engine. Since this mapping involves two OS-visible engines, managing them in parallel under one application is similar to the solution in earlier generations. Each engine has its own command streamers and has mechanisms to synchronize at required levels as described in the next sub-section.

Above three steps of encoding have dependencies in processing based on

- i. functional pipeline order, *i.e.* on a given frame, VPP needs to be performed first, then ENC, then PAK and finally MFD (*Multi-Format Decoding*) for key reference frame generation.
- ii. I-frames are key frames for P and B, they have to be first in every pipe-stage.
- iii. P-frames are key frames for B frames and therefore P frames are processed first before the dependent B frames
- iv. GFX Engine is time slice to work on either VPP or ENC frame as we discussed in the previous chapter.
- v. PAK + MFD are executed on the same frame in the MFX engine by macro-block level pipelining within a slice. It should be noted that for the sake of simplicity, an entire frame (potentially multiple slices) are processed in the corresponding engine and no smaller granularity of switching is allowed between the functional pipeline stages.



Three steps of the encoding can be interleaved on two engines in the following way on a frame by frame basis.

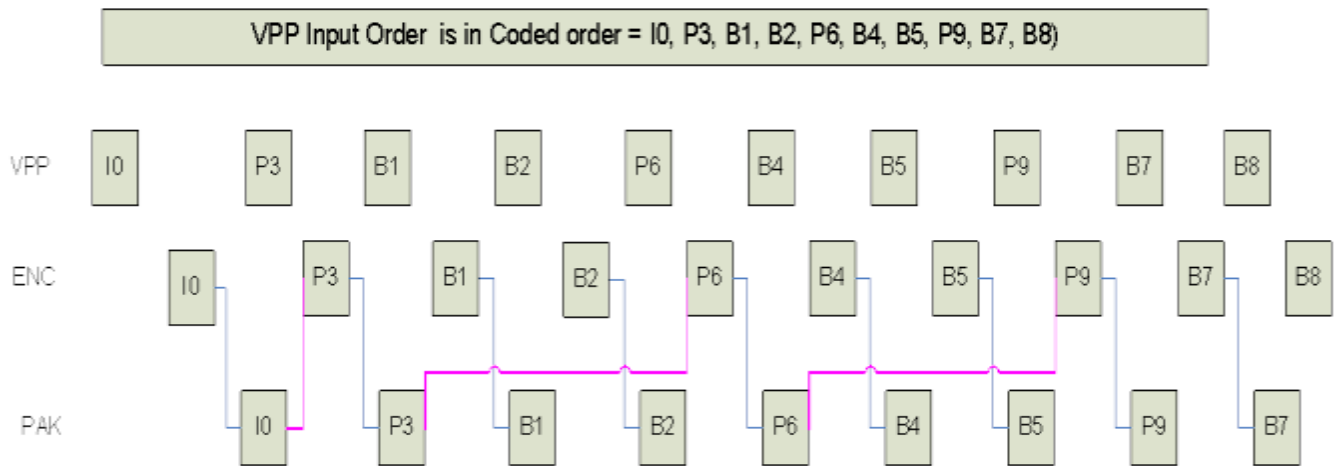

Command Stream Synchronization



Restrictions

MFC implementation is subject to the following limitations.

- Context switching within MFC and with Graphics Engine occurs only at frame boundary to minimize the amount of information that needs to be tracked and maintained.

MFD Overview

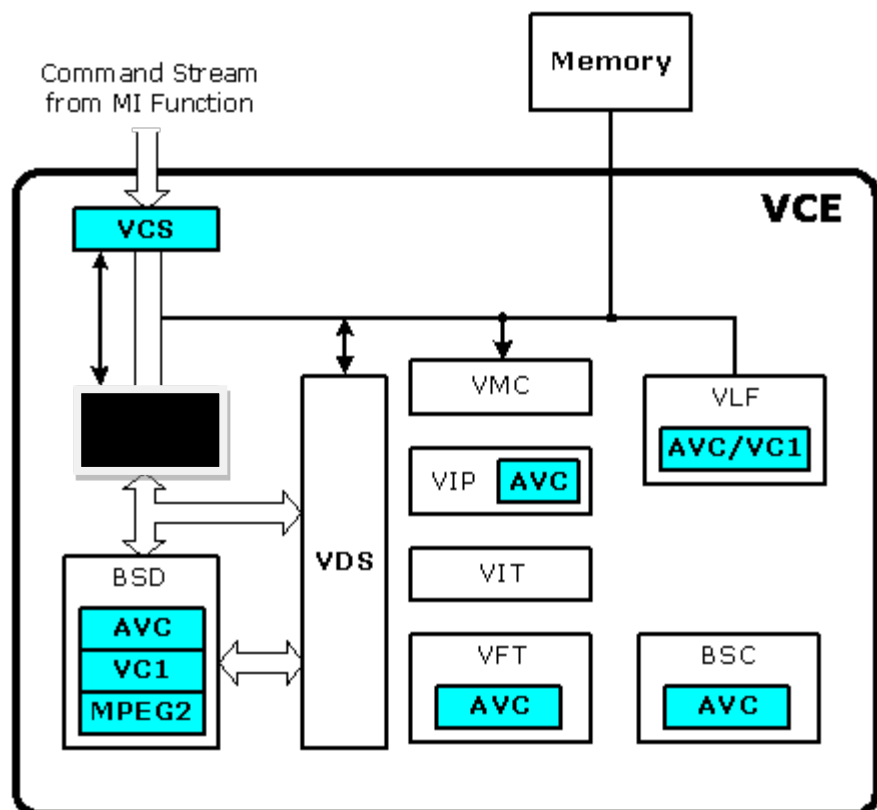

B6681-01

When used for decoding, we refer MFX Engine also as MFD Engine.

The Multi-Format Decoder (MFD) is a hardware fixed function pipeline for decoding the three video codec formats and one image compression codec format : AVC (H.264), SVC, VC-1, MPEG2 and JPEG.

- Compliant with next generation high definition optical video disc requirements, with sufficient performance headroom:
 - Support AVC 4:2:0 Main and High (8-bit only) Profile only (no support for Baseline, Extended and High-10 Profiles), up to Level 5.1 (max 983,040 MB/s, max 36,864 MB/frame, and at most one dimension can reach 4K pixel) resolution and up to 40 mbps bitstream. With sufficient duty cycles, higher bit rate contents can also be decoded.
 - Allow a B-picture (frame or field) as a reference picture
 - Starting with DevHSW, support MVC 4:2:0 Stereoscopic Progressive Profile only, up to Level 5.1 (max 983,040 MB/s per view, max 36,864 MB/frame per view, and at most one dimension can reach 4K pixel) resolution and up to 40 mbps bitstream. With sufficient duty cycles, higher bit rate contents can also be decoded.
 - Does not support interlaced video specified in the Stereoscopic Profile



Feature	Feature Description	Project
Interlace (MBAFF/PAFF)	Not Supported	EXCLUDE(HSW:GT3:A, HSW:GT3:B, HSW:GT2:B), HSW

- Support VC1 4:2:0 Simple, Main and Advanced Profiles, up to Level 4 (max 491,520 MB/s and max 16,384 MB/frame; max only one dimension will be at 4K pixel) resolution and up to 40 mbps bitstream. With sufficient duty cycles, higher bit rate contents can also be decoded.
 - Allow a B-field as a reference picture only in interlaced field decoding, no other modes.
- Support MPEG2 HD Main Profile (4:2:0), up to High Level (1920x1152 pixels) and up to 80 mbps bitstream. With sufficient duty cycles, higher bit rate contents can also be decoded. No support for SNR and spatial-scalability.
 - Does not support B-picture as a reference picture.
- Support Baseline JPEG with five chroma types (4:0:0, 4:1:1, 4:2:2, 4:2:0, and 4:4:4. No support for Extended DCT-based mode, Progressive mode, Lossless mode, nor Hierarchical mode
 - H/W support 64Kx64K, but Surface State can support only up to 16kx16k

Features	Supported	Unsupported
Coding processes	Baseline sequential mode: <ul style="list-style-type: none"> • 8-bit pixel precision of source images • loadable 2 AC and 2 DC Huffman tables • 3 loadable quantization matrix for Y, U, V • Interleaved and non-interleaved Scans • Single and multiple Scans 	Extended DCT-based mode, Lossless, Hierarchical modes: More than 8 bit pixel resolution, progressive mode, arithmetic coding, 4 AC and 4 DC Huffman tables (extended mode), predictive process (lossless), multiple frames (hierarchical)
Number of image channels	1 for grey image 3 for Y, Cb, Cr color image	4-th channel (usually alpha blending image)
Image resolution	Arbitrary image size up to 16K * 16K	Larger than 16K * 16K (64K * 64K is max. in the JPEG standard)



Features	Supported	Unsupported
Chroma subsampling ratio	Chroma 4:0:0 (grey image) Chroma 4:1:1 Chroma 4:2:0 Chroma horizontal 4:2:2 Chroma vertical 4:2:2 Chroma 4:4:4	Any other arbitrary ratio, e.g., 3:1 subsampled chroma
Additional feature (post-processing)	Image rotation: 90/180/270 degrees	

- H/W does not impose restriction on picture frame aspect ratio, but is bounded by a max 256 MBs (4096 pixels) per dimension programmable at the H/W interface specifications.
 - For example, supporting HD video resolution 1920x1080/60i, 1920x1080/24p, 1280x720/60p
- Performance requirements with MFX core frequency above 1GHz
 - Real-time performance around 10% duty cycle
 - Support concurrently decoding of at least two active HD bitstreams of different formats (For example, one AVC and one VC1 HD bitstream)
- The parsing of transport layer and sequence layer is not performed in this hardware, and is required to be done in the host software.
- The MFD hardware pipeline is operated concurrently with and independently from the Graphics (3D/Media) pipeline with separate command streamer. The two parallel engines are designed with the similar command protocol. They can be executed in parallel with different context.
- Local storages and buffers along the hardware pipeline are kept at minimum. For example, there is no on-die row-store memory. They are resided on the system memory. MFD is designed to hide the memory access latency (in both the row stores and in the motion compensation units) in maximizing its decoding throughput.
- Support the following operating modes
 - VLD mode – operation starts from entropy decoding of the compressed bit stream (parsing Slice Header and Slice Data Layer in AVCand MVC (HSW), Picture layer, Slice layer and MB Layer in VC-1, and MB-layer in MPEG2), all the way, to the reconstruction of display picture, including in-loop and out-loop deblocking, if any.
 - Streamout mode – a new feature of the VLD mode in assisting transcoding during decoding. Selected uncompressed data (e.g. per MB MV information) will be sent out to the EU and the ME engine (resided on the Sampler of the 3D Gx Pipeline) for encoding into a different format or for the purpose of transcaling and transrating. In addition, the uncompressed result may continue to be processed by



the rest of pipeline as in VLD mode to generate the display picture for transcoding. That is, while intermediate data are streaming out to the memory, the MFD Engine continues its decoding as usual.

- For JPEG, only VLD mode is supported (No IT mode). Host software decodes Frame and Scan layers (down to Scan header in the JPEG bit stream syntax) and sends all the corresponding information and Scan payload to the MFD hardware pipeline.
- IT mode – when host software has already performed all the bit stream parsing of the compressed data and packaging the uncompressed result into a specific format (as a sequence of per-MB record) stored in memory. The hardware pipeline will fetch one MB record at a time and perform the rest of the decoding process as in VLD mode
- Host software (Application) is responsible for parsing and decoding all the transport and program layers, and all sequence layers. These parameters are passed to Driver and forwarded to H/W as needed through different STATE commands. Host software is also responsible for separating non-video data (audio, meta and user data) from sending to H/W.
 - MFD Engine is only responsible for macro-block and block layers decoding, plus certain level of header decoding. For AVC and MVC (HSW),MFD starts decoding from Slice Header; for VC1, MFD starts decoding from Picture Header, and for MPEG2 decoding starts from MB Layer only.
 - For JPEG, MFD is responsible for ECS and block layers decoding.
- Support bitstream formats (compressed video data) for each codec
 - AVC – 2 formats
 - MVC – 2 formats
 - DXVA2 MVC Short Slice Format (HSW onwards)
 - DXVA2 AVC Long Slice Format Specification (exactly the same as AVC)
 - VC1 – 2 formats
 - Fully compliant to Picture Parameter and Slice Control Parameter interface definition
 - MPEG2
 - MB Layer only, according to DXVA 1 Specification
 - JPEG
 - ECS Layer
- The MFX codec is designed to be a stateless engine, that it does not retain any history of settings (states) for the encoding/decoding process of a picture. Hence, driver must issue the full set of



MFX picture state command sequence prior to process each new picture. In addition, driver must issue the full set of Slice state command sequence prior to process a slice.

- In particularly, RC6 always happens between frame boundaries. So at the beginning of every frame, all state information needs to be programmed. There is no state information as part of media context definition.
- To activate the AVC deblocker logic for incoming uncompressed 4:2:0-only video stream, one can pack the uncompressed video stream to compliant with the IPCM MB data format (including ILDB control information) and feed them into the MFD engine in IT mode. Since the MFD Engine is in IPCM mode, transformation, inter and intra processing are all inactive.

Start Code Detection and removal are done in the CPU, but the Start Code Emulation Prevention Byte is detected and removed by the front end logic in the MFD. The bitstream format for each codec and for each mode is specified in this document.

Codec specific information are based on the following released documents from third parties :

- Draft of Version 4 of H.264/AVC (ITU-T Recommendation H.264 and ISO/IEC 14496-10 (MPEG-4 part 10) Advanced Video Coding); JVT-O205d1.doc; dated 2005-05-30
- Final Draft SMPTE Standard : VC1 Compressed Video Bitstream Format and Decoding Process, SMPTE 421M, dated 2006-1-6; PDF file.
- MPEG2 Recommendation ITU T H.262 (1995 E), ISO/IEC 13818-2: 1995 (E); doc file.
- Digital Compression and Coding of Continuous-tone Still Images, ITU-T Rec. T.81 and ISO/IEC 10918-1: Requirements and guidelines September 18 1992; itu-t81[1].pdf



MFD Memory Interface

The Memory Arbitrator follows the pre-defined arbitration policy (as indicated in the following listing P0 to P11, in which P0 is the highest priority) to select the next memory request to service, then it will perform the TLB translation (translation to physical address in memory), and make the actual request to memory.

The Memory Arbitration unit is also responsible for capturing the return data from memory (read request) and forward it to the appropriate unit along the MFD Engine.

- Read streams: (all 64B requests)
 - Commands for BSD : linear (including indirect data) (P0)
 - Indirect DMA (P1)
 - Row store for BSD: linear (P5)
 - Row store for MPR: linear (P6)
 - MC ref cache fetch : tiled (P2)
 - Intra row store: linear (P9)
 - ILDB row store: linear (P10)
- Write streams: (all 64B requests)
 - Row store write for BSD: linear and can avoid partial writes (P3)
 - Row store write for MPR: linear and can avoid partial writes (P4)
 - Intra row store write: linear and can avoid partial writes (P7)
 - ILDB row store write: linear and can avoid partial writes (P8)
 - Final dest writes: tiled and can potentially be partial, two ways to avoid these partials: 1) either write garbage and buffers are aligned or 2) read-modify writes for dribble end of line cases (P11)



MFD Codec-Specific Commands

MFD hardware pipeline supports 3 different codec standards : AVC, VC1 and MPEG2. To make the interface flexible, each codec is designed with its own set of commands.

There are two categories of commands for each codec format : one set for VLD mode and one set for IT mode.



MFX Interruptability Model

MFX encoding and the encoding pipeline do not support interruption. All operations are frame based. Interrupts can only occur between frames; the driver will submit all the states at the beginning of each frame. Any state kept across frames is in MMIO registers that should be read between frames.

Software submits without any knowledge of where the parser head pointer is located. Also there is a non-deterministic amount of time for the new context to reach the command streamer. However, the state model for the MFX engine requires software to know exactly what state the pipeline is in at all times. This introduces cases where a preemption could occur during or after a state change without software ever knowing the state saved out to memory on the context switch.

Also, preemption is only allowed during the last macroblock in a row. Hardware cannot always perform a context switch when the new context is seen by the hardware. To avoid a switch during an invalid macroblock and to keep the state synchronized with software, there are two commands available that are used. MI_ARB_ON_OFF disables and enables preemption while MFX_WAIT ensures the context switch, if needed, preempts during macroblock execution. Below illustrates an example assuming VC1 VLD mode.

Command Ring/Batch	Notes
MI_ARB_ON_OFF = OFF	Disable preemption
S1	Inline or indirect state cmd 1
S2	Inline or indirect state cmd 2
S3	Inline or indirect state cmd 3
XXXX_OBJECT	Slice
MI_ARB_ON_OFF = ON	Enable preemption
MFX_WAIT	Allow preemption to occur while XXXX_OBJECT executes
MI_ARB_ON_OFF = OFF	Since arbitration is off again, state commands are allowed below
S4	Inline or indirect state cmd 4
S5	Inline or indirect state cmd 5
S6	Inline or indirect state cmd 6
XXXX_OBJECT	Slice
MI_ARB_ON_OFF = ON	Enable preemption
MFX_WAIT	Allow preemption to occur while XXXX_OBJECT executes
MI_ARB_ON_OFF = OFF	Since arbitration is off again, state commands are allowed below

Note that store DW commands may execute inside the preemption enabling window if needed.



Decoder Input Bitstream Formats

AVC Bitstream Formats – DXVA Short

Bitstream Buffer Address starts after the 3-byte start code, i.e. starts (and includes) at the NAL Header Byte. This byte must not be included in the Emulation Byte Detection Process.

AVC Bitstream Formats – DXVA Long

Bitstream Buffer Address starts after the 3-byte start code, i.e. starts (and includes) at the NAL Header Byte. This byte must not be included in the Emulation Byte Detection Process. Application will provide the Slice Header Skip Byte count (not including any possible Emulation Prevention Byte).

VC1 Bitstream Formats – Intel Long

Bitstream starts right at the MB layer, with any emulation byte crossing the header and MB layer being removed by application and the data length is adjusted.

MPEG2 Bitstream Formats – DXVA1

Bitstream buffer starts right at the very first MB data.

JPEG Bitstream Formats – Intel

Bitstream buffer starts right at the very first MCU data of each Scan.

The indirect data start address in MFD_JPEG_BSD_OBJECT specifies the starting Graphics Memory address of the bitstream data that follows the Scan header. It provides the byte address for the first MCU of the Scan. Different from MFD_MPEG2_BSD_OBJECT command, First MCU Bit Offset does not need to be specified because it is always set to zero.

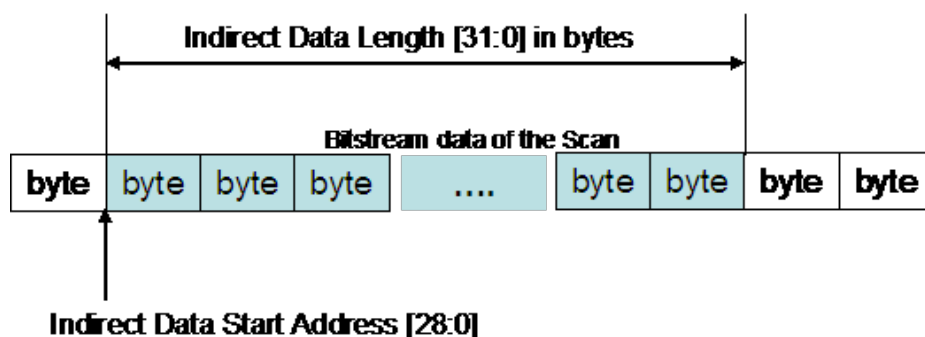

Indirect data buffer for a Scan

The indirect data length in MFD_JPEG_BSD_OBJECT provides the length in bytes of the bitstream data for the Scan excluding Scan header. It includes the first byte of the first macroblock and the last byte of the last macroblock in the Scan. The Figure illustrates these parameters for a slice data.



Concurrent, Multiple Video Stream Decoding Support

The natural place for switching across multiple streams is at the Slice boundary. Each Slice is a self-sustained unit of compressed video data and has no dependency with its neighbors (except for the Deblocking process). In addition, there is no interruptability within a Slice. However, when ILDB is invoked, the processing of some MBs will require neighbour MB information that crosses the Slice boundary. Hence, to limit the buffering requirement, in this version of hardware design, stream switching can only be performed at the picture boundary instead.



MFX Codec Commands Summary

DWord	Bit	Description
0	31:29	Instruction Type = GFXPIPE = 3h
	28:16	3D Instruction Opcode = PIPELINE_SELECT GFXPIPE[28:27 = 1h, 26:24 = 1h, 23:16 = 04h] (Single DW, Non-pipelined)
	15:1	Reserved: MBZ
	0	Pipeline Select 0: 3D pipeline is selected 1: Media pipeline is selected

Pipeline Type (28:27)	Opcode (26:24)	Sub Opcode (23:16)	Command	Definition Chapter
VC1 State				
2h	5h	0h	VC1_BSD_PIC_STATE	VC1 BSD
2h	5h	1h	Reserved	n/a
2h	5h	2h	Reserved	n/a
2h	5h	3h	VC1_BSD_BUF_BASE_STATE	VC1 BSD
2h	5h	4h	Reserved	n/a
2h	5h	5h-7h	Reserved	n/a
VC1 Object				
2h	5h	8h	VC1_BSD_OBJECT	VC1 BSD
2h	5h	9h-FFh	Reserved	n/a

Pipeline Type (28:27)	Opcode (26:24)	Sub Opcode (23:16)	Command	Definition Chapter
State				
2h	6h	2h-7h	Reserved	N/A
Object				
2h	6h	9h-FFh	Reserved	N/A



Note that it is possible for a command to appear in both IMAGE and SLICE state buffer, e.g. QM_STATE for JPEG can be issued at frame level or scan/slice level.

Pipeline Type (28:27)	Opcode (26:24)	SubopA (23:21)	SubopB (20:16)	Command	Chapter	Recommended Indirect State Pointer Map	Interruptable?
	MFX Common	Common					
2h	0h	0h	0h	MFX_PIPE_MODE_SELECT	MFX	IMAGE	No
2h	0h	0h	1h	MFX_SURFACE_STATE	MFX	IMAGE	No
2h	0h	0h	2h	MFX_PIPE_BUF_ADDR_STATE	MFX	IMAGE	No
2h	0h	0h	3h	MFX_IND_OBJ_BASE_ADDR_STATE	MFX	IMAGE	No
2h	0h	0h	4h	MFX_BSP_BUF_BASE_ADDR_STATE	MFX	IMAGE	No
2h	0h	0h	6h	MFX_STATE_POINTER	MFX	IMAGE	No
2h	0h	0h	7h	MFX_QM_STATE	MFX	IMAGE/SLICE	No
2h	0h	0h	8h	MFX_FQM_STATE	MFX	IMAGE	No
2h	0h	0h	9h	MFX_DBK_OBJECT	MFX	IMAGE	No
2h	0h	0h	A-1Eh	Reserved	n/a	n/a	No
	MFX Common	Dec					
2h	0h	1h	0-8h	Reserved	n/a	n/a	n/a
2h	0h	1h	9h	MFD_IT_OBJECT	MFX	n/a	No
2h	0h	1h	A-1Fh	Reserved	n/a	n/a	n/a
	MFX Common	Enc					
2h	0h	2h	0-7Fh	Reserved	n/a	n/a	n/a
2h	0h	2h	8h	MFX_PAK_INSERT_OBJECT	MFX	n/a	No
2h	0h	2h	9h	Reserved	n/a	n/a	n/a
2h	0h	2h	Ah	MFX_STITCH_OBJECT	MFX	n/a	No
2h	0h	2h	B-1Fh	Reserved	n/a	n/a	n/a
	AVC/ MVC/ SVC	Common (State)					
2h	1h	0h	0h	MFX_AVC_IMG_STATE	MFX	IMAGE	n/a
2h	1h	0h	1h	Reserved	n/a	n/a	n/a
2h	1h	0h	2h	MFX_AVC_DIRECTMODE_STATE	MFX	SLICE	n/a
2h	1h	0h	3h	MFX_AVC_SLICE_STATE	MFX	SLICE	n/a



Pipeline Type (28:27)	Opcode (26:24)	SubopA (23:21)	SubopB (20:16)	Command	Chapter	Recommended Indirect State Pointer Map	Interruptable?
	MFX Common	Common					
2h	1h	0h	4h	MFX_AVC_REF_IDX_STATE	MFX	SLICE	n/a
2h	1h	0h	5h	MFX_AVC_WEIGHTOFFSET_STATE	MFX	SLICE	n/a
2h	1h	0h	8h	MFX_SVC_IMG_STATE	MFX	IMAGE	n/a
2h	1h	0h	9	Reserved	n/a	n/a	n/a
2h	1h	0h	Ah	MFX_SVC_INTERLAYER_STATE	MFX	IMAGE	n/a
2h	1h	0h	Bh	MFX_SVC_INTERLAYER_MV_STATE	MFX	SLICE	n/a
2h	1h	0h	Ch	MFX_SVC_SLICE_STATE	MFX	SLICE	n/a
2h	1h	0h	D-1Fh	Reserved	n/a	n/a	n/a
	AVC/MVC	Dec					
2h	1h	1h	0-5h	Reserved	MFX	n/a	n/a
2h	1h	1h	6h	MFD_AVC_DPB_STATE	MFX	IMAGE	n/a
2h	1h	1h	7h	MFD_AVC_SLICEADDR_OBJECT	MFX	n/a	n/a
2h	1h	1h	8h	MFD_AVC_BSD_OBJECT	MFX	n/a	No
2h	1h	1h	9-1Fh	Reserved	n/a	n/a	n/a
	AVC/MVC	Enc					
2h	1h	2h	0-8h	Reserved	n/a	n/a	n/a
2h	1h	2h	9h	MFC_AVC_PAK_OBJECT	MFX	n/a	No
2h	1h	2h	A-1Fh	Reserved	n/a	n/a	n/a
	AVC/MVC	Extension					
2h	1h	3h	1h	MFX_SVC_INTERLAYER_OBJECT	MFX	SLICE	No
	VC1	Common (State)					
2h	2h	0h	0h	Reserved	n/a	n/a	n/a
2h	2h	0h	1h	MFX_VC1_PRED_PIPE_STATE	MFX	IMAGE	n/a
2h	2h	0h	2h	MFX_VC1_DIRECTMODE_STATE	MFX	SLICE	n/a
2h	2h	0h	3-1Fh	Reserved	n/a	n/a	n/a
	VC1	Dec					



Pipeline Type (28:27)	Opcode (26:24)	SubopA (23:21)	SubopB (20:16)	Command	Chapter	Recommended Indirect State Pointer Map	Interruptable?
	MFX Common	Common					
2h	2h	1h	0h	MFD_VC1_SHORT_PIC_STATE	MFX	IMAGE	n/a
2h	2h	1h	1h	MFD_VC1_LONG_PIC_STATE	MFX	IMAGE	n/a
2h	2h	1h	2-7h	Reserved	n/a	n/a	n/a
2h	2h	1h	8h	MFD_VC1_BSD_OBJECT	MFX	n/a	No
2h	2h	1h	9-1Fh	Reserved	n/a	n/a	n/a
	VC1	Enc					
2h	2h	2h	0-1Fh	Reserved	n/a	n/a	n/a
	MPEG2	Common (State)					
2h	3h	0h	0h	MFX_MPEG2_PIC_STATE	MFX	IMAGE	n/a
2h	3h	0h	1-1Fh	Reserved	n/a	n/a	n/a
	MPEG2	Dec					
2h	3h	1h	1-7h	Reserved	n/a	n/a	n/a
2h	3h	1h	8h	MFD_MPEG2_BSD_OBJECT	MFX	n/a	No
2h	3h	1h	9-1Fh	Reserved	n/a	n/a	n/a
	MPEG2	Enc					
2h	3h	2h	0-2h	Reserved	n/a	n/a	n/a
2h	3h	2h	3h	MFC_MPEG2_PAK_OBJECT			
2h	3h	2h	3-8h	Reserved			
2h	3h	2h	9h	MFC_MPEG2_SLICEGROUP_STATE			
2h	3h	2h	A-1Fh	Reserved			
	JPEG	Common					
2h	7h	0h	0h	MFX_JPEG_PIC_STATE	MFX	IMAGE	No
2h	7h	0h	1h	Reserved	n/a	n/a	n/a
2h	7h	0h	2h	MFX_JPEG_HUFF_TABLE_STATE	MFX	IMAGE	No
2h	7h	0h	3-1Fh	Reserved	n/a	n/a	n/a
	JPEG	Common					
2h	7h	0h	0h	MFX_JPEG_PIC_STATE	MFX	IMAGE	No
2h	7h	0h	1h	Reserved	n/a	n/a	n/a



Pipeline Type (28:27)	Opcode (26:24)	SubopA (23:21)	SubopB (20:16)	Command	Chapter	Recommended Indirect State Pointer Map	Interruptable?
	MFX Common	Common					
2h	7h	0h	2h	MFX_JPEG_HUFF_TABLE_STATE	MFX	IMAGE	No
2h	7h	0h	3-1Fh	Reserved	n/a	n/a	n/a
	JPEG	Dec					
2h	7h	1h	1-7h	Reserved	MFX	n/a	n/a
2h	7h	1h	8h	MFD_JPEG_BSD_OBJECT	MFX	MCU	No
2h	7h	1h	9-1Fh	Reserved	MFX	n/a	n/a
	JPEG	Enc					
2h	7h	2h	0-1Fh	Reserved	MFX	n/a	n/a



MMIO Space Registers

Range Start	Range End	Unit owner
00002000	00002FFF	Render/Generic Media Engine
00004000	00004FFF	Render/Generic Media Graphics Memory Arbiter
00005000	0000517F	
00006000	00007FFF	Reserved
00012000	000123FF	MFX Control Engine (Video Command Streamer)
00012400	00012FFF	Media Units (VIN unit)
00014000	00014FFF	MFX Memory Arbiter
00022000	00022FFF	Blitter Engine
00024000	00024FFF	Blitter Memory Arbiter
00030000	0003FFFF	Reserved
00100000	00107FFF	Fence Registers
00140000	0017FFFF	MCHBAR (SA)

Memory Interface Command Map

04h Opcode (28:23)	MI_FLUSH
--------------------	----------



MFX Decoder Commands Sequence

The MFX codec is designed to be a stateless engine, that it does not retain any history of settings (states) for the encoding/decoding process of a picture. Hence, driver must issue the full set of MFX picture state command sequence prior to process each new picture. In addition, driver must issue the full set of Slice state command sequence prior to process a slice.

In particular, RC6 always happens between frame boundaries. So at the beginning of every frame, all state information needs to be programmed. There is no state information as part of media context definition



Examples for AVC

The following gives a sample command sequence programmed by a driver

a) For Intel or DXVA2 AVC Long Slice Bitstream Format

```
MFX_PIPE_MODE_SELECT
MFX_SURFACE_STATE
MFX_PIPE_BUF_ADDR_STATE
MFX_IND_OBJ_BASE_ADDR_STATE
MFX_BSP_BUF_BASE_ADDR_STATE
MFX_QM_STATE
VLD mode: MFX_AVC_PICID_STATE
MFX_AVC_IMG_STATE
MFX_AVC_DIRECTMODE_STATE
MFX_AVC_REF_IDX_STATE
MFX_AVC_WEIGHTOFFSET_STATE
MFX_AVC_SLICE_STATE
VLD mode: MFD_AVC_BSD_OBJECT
IT mode: MFD_IT_OBJECT
MI_FLUSH
```

b) For DXVA2 AVC Short Slice Bitstream Format (for VLD mode only)

```
MFX_PIPE_MODE_SELECT
MFX_SURFACE_STATE
MFX_PIPE_BUF_ADDR_STATE
MFX_IND_OBJ_BASE_ADDR_STATE
MFX_BSP_BUF_BASE_ADDR_STATE
MFD_AVC_DPB_STATE
VLD mode: MFX_AVC_PICID_STATE
MFX_AVC_IMG_STATE
MFX_QM_STATE
MFX_AVC_DIRECTMODE_STATE
```



VLD mode : MFD_AVC_SLICEADDR_OBJECT

VLD mode: MFD_AVC_BSD_OBJECT

VLD mode : MFD_AVC_BSD_SLICEADDR_OBJECT

VLD mode: MFD_AVC_BSD_OBJECT

... repeat these four commands N-1 times for a N-slice picture

VLD mode: MFD_AVC_BSD_OBJECT (for the last slice of the picture)

MI_FLUSH



Examples for VC1

The following gives a sample command sequence programmed by a driver

a) For Intel Proprietary Long Bitstream Format

```
MFX_VC1_DIRECTMODE_STATE
MFX_VC1_PRED_PIPE_STATE
MFX_VC1_LONG_PIC_STATE
VLD mode: MFD_VC1_BSD_OBJECT
IT mode: MFD_IT_OBJECT
MI_FLUSH
```

b) For DXVA2 VC1 Compliant Bitstream Format (for VLD mode only)

```
MFX_VC1_DIRECTMODE_STATE
MFX_VC1_PRED_PIPE_STATE
MFX_VC1_SHORT_PIC_STATE
VLD mode: MFD_VC1_BSD_OBJECT
MI_FLUSH
```

c) For DXVA2 VC1 Compliant Bitstream Format (for VLD mode only), and field pair picture

```
Batch buffer for top-field
states...
Slice_objs...
MI_flush
store register immediate (if VC1 short format with interlaced field pic)
MI_flush
Batch buffer for bottom field
load register immediate (if VC1 short format with interlaced field pic)
MI_flush
states...
Slice_objs...
MI_flush
```



Examples for JPEG

The following gives a sample command sequence programmed by a driver

Programmed once at the start of decoding

```
MFX_PIPE_MODE_SELECT
MFX_PIPE_SURFACE_STATE
MFX_IND_OBJ_BASE_ADDR_STATE
MFX_PIPE_BUF_ADDR_STATE
MFX_JPEG_PIC_STATE
```

Programmed at the start of Frame or Scan (These commands can be sent multiple times either before MFX_JPEG_PIC_STATE or before MFD_JPEG_BSD_OBJECT)

```
MFX_JPEG_HUFF_TABLE
MFX_QM_STATE
```

Programmed per Scan (These commands can be sent multiple times depending on each bit stream)

```
MFD_JPEG_BSD_OBJECT
MI_FLUSH
```



Examples of SVC Command Sequences

1) No StreamIn ; optional StreamOut			
2) Optional StreamIn ; optional StreamOut			
3) Optional StreamIn ; no StreamOut			
Case 1	BaseLayer as the Target Layer		
		Decode or Encode exactly as AVC Long or Short VLD Format : w/o transcoding StreamOut and w/o standalone deblocking StreamOut	
Case 2	BaseLayer as the lowest layer : Dec or Enc (CurrDQId=0)		
	Frame Level (these states are for currlayer, which is a baselayer) :		
		MFX_PIPE_MODE_SELECT Command	
		MFX_PIPE_SURFACE_STATE Command	
		MFX_PIPE_SURFACE_STATE Command	
		MFX_PIPE_BUF_ADDR_STATE Command	(enable standalone deblocking StreamOut even the current decoding session has deblocking turned on; disable transcoding streamout)
		MFX_IND_OBJ_BASE_ADDR_STATE Command	
		MFX_BSP_BUF_BASE_ADDR_STATE Command	
		MFX_QM_STATE (and MFX_FQM_STATE for encoder) Command	
		MFX_AVC_IMG_STATE Command	(enable on-the-fly interlayer deblocking mode 0 to 2)
	Slice Level : Slice 1 (these states are for currlayer, which is a baselayer)		



		MFX_AVC_DIRECTMODE_STATE Command	
		MFX_AVC_REF_IDX_STATE Command	
		MFX_AVC_WEIGHTOFFSET_STATE Command	
		MFX_AVC_SLICE_STATE Command	(Base Layer & Enh Layer & QBL Layer & Target Layer)
		MFD_AVC_BSD_OBJECT/MFC_AVC_PAK_OBJECT Command	(Base Layer & Enh Layer & QBL Layer & Target Layer)
		MI_FLUSH Command	
	Slice Level : Slice 2 (these states are for currlayer, which is a baselayer)		
		MFX_AVC_DIRECTMODE_STATE Command	
		MFX_AVC_REF_IDX_STATE Command	
		MFX_AVC_WEIGHTOFFSET_STATE Command	
		MFX_AVC_SLICE_STATE Command	(Base Layer & Enh Layer & QBL Layer & Target Layer)
		MFD_AVC_BSD_OBJECT/MFC_AVC_PAK_OBJECT Command	(Base Layer & Enh Layer & QBL Layer & Target Layer)
		MI_FLUSH Command	
	Frame Level : Standalone Deblocker (these states are for currlayer, which is a baselayer)		
		MFX_PIPE_MODE_SELECT Command	(set for standalone deblocker mode)
		MFX_PIPE_SURFACE_STATE Command	
		MFX_AVC_IMG_STATE Command	(set for interlayer deblocking mode 3 to 6)
		MFX_DBK_OBJECT Command	(set the Deblocker Control StreamIn Buffer)
		MI_FLUSH Command	



Case 3	Interlayer (Upsampling) Pipe Mode		
	Frame Level (these states are for current enhancement layer (not yet decoded) and its reference layer (already decoded)) :		
		MFX_PIPE_MODE_SELECT Command	
		MFX_PIPE_SURFACE_STATE Command	
		MFX_PIPE_SURFACE_STATE Command	
		MFX_PIPE_SURFACE_STATE Command	
		MFX_PIPE_SURFACE_STATE Command	
			(not using transcoding and standalone deblocking StreamOut)
		MFX_AVC_IMG_STATE Command	(Base Layer & Enh Layer & QBL Layer & Target Layer)
	Slice Level : Slice 1		
		MFX_AVC_REF_IDX_STATE Command	
		MFX_AVC_SLICE_STATE Command	
	Slice Level : Slice 2		
		MFX_AVC_REF_IDX_STATE Command	
		MFX_AVC_SLICE_STATE Command	
		MI_FLUSH Command	
Case 4	Spatial or Quality Enhancement layer and not Target/QBL Layer : Dec or Enc (CurrDQId>0)	(QBL is decoded in 2 passes; this is the 2nd pass takes the same streamin as in the 1st pass and generate the streamout for next layer)	
	Frame Level (these states are for currlayer) :		



		MFX_PIPE_MODE_SELECT Command	
		MFX_PIPE_SURFACE_STATE Command	
		MFX_PIPE_SURFACE_STATE Command	
		MFX_PIPE_SURFACE_STATE Command	
		MFX_PIPE_SURFACE_STATE Command	
		MFX_PIPE_BUF_ADDR_STATE Command	(enable standalone deblocking StreamOut even the current decoding session has deblocking turned on ; disable transcoding streamout)
		MFX_IND_OBJ_BASE_ADDR_STATE Command	
		MFX_BSP_BUF_BASE_ADDR_STATE Command	
		MFX_QM_STATE (and MFX_FQM_STATE for encoder) Command	
		MFX_AVC_IMG_STATE Command	(enable on-the-fly interlayer deblocking mode 0 to 2)
	Slice Level : Slice 1 (these states are for currlayer)		
		MFX_AVC_SLICE_STATE Command	
		MFD_AVC_BSD_OBJECT/MFC_AVC_PAK_OBJECT Command	
	Slice Level : Slice 2 (these states are for currlayer)		
		MFX_AVC_SLICE_STATE Command	(Base Layer & Enh Layer & QBL Layer & Target Layer)
		MFD_AVC_BSD_OBJECT/MFC_AVC_PAK_OBJECT Command	(Base Layer & Enh Layer & QBL Layer & Target Layer)
		MI_FLUSH Command	
	Frame Level : Standalone Deblocker (these states are for currlayer)		
		MFX_PIPE_MODE_SELECT Command	(set for standalone deblocker mode)



		MFX_PIPE_SURFACE_STATE Command	
		MFX_AVC_IMG_STATE Command	(set for interlayer deblocking mode 3 to 6)
		MFX_DBK_OBJECT Command	(set the Deblocker Control StreamIn Buffer)
		MI_FLUSH Command	
Case 5	Target/QBL Layer : Dec or Enc (CurrDQId>0)	(QBL is decoded in 2 passes; this is the 1st pass takes the streamin and generate a decoded picture)	
	Frame Level (these states are for currlayer) :		
		MFX_PIPE_MODE_SELECT Command	
		MFX_PIPE_SURFACE_STATE Command	
		MFX_PIPE_SURFACE_STATE Command	
		MFX_PIPE_SURFACE_STATE Command	
		MFX_PIPE_SURFACE_STATE Command	
		MFX_PIPE_BUF_ADDR_STATE Command	(enable standalone deblocking StreamOut even the current decoding session has deblocking turned on ; enable transcoding streamout)
		MFX_IND_OBJ_BASE_ADDR_STATE Command	
		MFX_BSP_BUF_BASE_ADDR_STATE Command	
		MFX_QM_STATE (and MFX_FQM_STATE for encoder) Command	
		MFX_AVC_IMG_STATE Command	(enable on-the-fly interlayer deblocking mode 0 to 2)
	Slice Level : Slice 1 (these states are for currlayer)		
		MFX_AVC_DIRECTMODE_STATE Command	
		MFX_AVC_REF_IDX_STATE Command	



		MFX_AVC_WEIGHTOFFSET_STATE Command	
		MFX_AVC_SLICE_STATE Command	
		MFD_AVC_BSD_OBJECT/MFC_AVC_PAK_OBJECT Command	
	Slice Level : Slice 2 (these states are for currlayer)		
		MFX_AVC_DIRECTMODE_STATE Command	
		MFX_AVC_REF_IDX_STATE Command	
		MFX_AVC_WEIGHTOFFSET_STATE Command	
		MFX_AVC_SLICE_STATE Command	s
		MFD_AVC_BSD_OBJECT/MFC_AVC_PAK_OBJECT Command	
		MI_FLUSH Command	
	Frame Level : Standalone Deblocker (these states are for currlayer)		
		MFX_PIPE_MODE_SELECT Command	(set for standalone deblocker mode)
		MFX_PIPE_SURFACE_STATE Command	
		MFX_AVC_IMG_STATE Command	(set for interlayer deblocking mode 3 to 6)
		MFX_DBK_OBJECT Command	(set the Deblocker Control StreamIn Buffer)
		MI_FLUSH Command	



MFX Pipe Common Commands

MFX Commands are organized into groups based on their scope of functioning. There are Pipeline Common state commands that are common to all codecs (encoder and decoder) and is applicable to the processing of one full frame/field. There are also individual codec Common state commands that are common to both encoder and decoder of that particular codec. These latter common state commands, some are applicable at the processing of one full frame/field, and some are applicable at the processing of an individual slice level.

MFX_STATE_POINTER]

MFX_PIPE_MODE_SELECT

Project:	HSW
The Encoder Pipeline Modes of Operation (Per Frame):	
<ol style="list-style-type: none">1. PAK Mode: VCS-command driven, setup by driver. Like the IT mode of decoder, it is executed on a per-MB basis. Hence, each PAK Object command corresponds to coding of only one MB.<ol style="list-style-type: none">a. Normal Mode (including transcoding): receive per-MB control and data (MV, mb_type, cbp, etc.). It generates the output compressed bitstream as well as the reconstructed reference pictures, one MB at a time, for later use.b. Encoder StreamOut Mode: to provide per-MB, per-Slice and per-Frame coding result and information (statistics) to the Host, Video Preprocessing Unit and ENC Unit to enhance their operations.	

Project:	HSW
The Decoder Pipeline Modes of Operation (Per Frame):	
<ol style="list-style-type: none">1. VLD Mode: The output from the BSD (weight&offset/coeff/motion vectors record) can be sent in part (as specified) and to the remaining fixed function hardware pipeline to complete the decoding processing. The driver specifies through MFD commands of what to send out from the BSD unit and where to send the BSD output.<ol style="list-style-type: none">a. For transcoding (including transrating and transcaling), part of the BSD output (a series of per-MB record) can be sent to memory for further processing to encode into a difference output format. This function is named as StreamOut. When StreamOut is active, not all MB information needs to be sent, only MVs and selective MB coding information.2. IT Mode: In this mode, the BSD is not invoked. Instead host performs all the bitstream decoding and parsing; and the result are saved into memory in a specific per-MB record format. The MFD Engine VCS reads in these records one at time and finish the rest of the decoding (IT, MC, IntraPred and ILDB).<ol style="list-style-type: none">a. MB information is organized into two indirect data buffers, one for MVs and one for residue coefficients. As such, two indirect base address pointers are defined.	



Programming Restriction:

- Software must ensure the current pipeline is flushed via an MI_FLUSH prior to the execution of MFX_PIPE_MODE_SELECT in switching the MFX Engine to encode/decode a different codec format (AVC, VC1 or MPEG2).
- MFX_PIPE_MODE_SELECT is issued per picture (frame or field).

MFX_SURFACE_STATE]

MFX_PIPE_BUF_ADDR_STATE

MFX_IND_OBJ_BASE_ADDR_STATE

MFX_BSP_BUF_BASE_ADDR_STATE

MFX_PAK_INSERT_OBJECT

MFX_STITCH_OBJECT]

MFX_QM_STATE

Bits	31:24	23:16	15:8	7:0	Project
Dword 1	QuantMatrix[0][3]	QuantMatrix[0][2]	QuantMatrix[0][1]	QuantMatrix[0][0]	HSW
Dword 2	QuantMatrix[0][7]	QuantMatrix[0][6]	QuantMatrix[0][5]	QuantMatrix[0][4]	HSW
Dword 3	QuantMatrix[1][3]	QuantMatrix[1][2]	QuantMatrix[1][1]	QuantMatrix[1][0]	HSW
...
Dword 16	QuantMatrix[7][7]	QuantMatrix[7][6]	QuantMatrix[7][5]	QuantMatrix[7][4]	HSW



MFX_QM_STATE

Project:

HSW

This is a frame-level state. Reciprocal Scaling Lists are always sent from the driver regardless whether they are specified by an application or the default/flat lists are being used. This is done to save the ROM (to store the default matrices) inside the PAK Subsystem. Hence, the driver is responsible for determining the final set of scaling lists to be used for encoding the current slice, based on the AVC Spec (Fall-Back Rules A and B). For encoding, there is no need to send the `qm_list_flags[i]`, $i=0$ to 7 and `qm_present_flag` to the PAK, since Scaling Lists syntax elements are encoded above Slice Data Layer.

FQM Reciprocal Scaling Lists elements are 16-bit each, conceptually equal to $1/\text{ScaleValue}$. QM matrix elements are 8-bit each, equal to ScaleValue . However, in AVC spec., the Reciprocal Scaling Lists elements are not exactly equal to one-over of the corresponding Scaling Lists elements. The numbers are adjusted to simplify hardware implementation.

For all the description below, a scaling list set contains 6 4x4 scaling lists (or forward scaling lists) and 2 8x8 scaling lists (or forward scaling lists).

In MFX PAK mode, PAK needs both forward Q scaling lists and IQ scaling lists. The IQ scaling lists are sent as in MFD in raster scan order as shown in `MFX_AVC_QM_STATE`. But the Forward Q scaling lists are sent in transport form, i.e. column-wise raster order (column-by-column) to simplify the H/W.

Precisely, if the reciprocal forward scaling matrix is $F[4][4]$, then the 16 word of the matrix will be set as the following:

For DevHSW:

	bits 0-15	bits 16-31
DW0	F[0][0]	F[1][0]
DW1	F[2][0]	F[3][0]
DW2	F[0][1]	F[1][1]
DW3	F[2][1]	F[3][1]
DW4	F[0][2]	F[1][2]
DW5	F[2][2]	F[3][2]
DW6	F[0][3]	F[1][3]
DW7	F[2][3]	F[3][3]



Bitplane Buffer

Bitplane coding is used in seven different cases in VC-1, although not all the seven syntax elements are present in the same picture header at the same time. The following list shows which syntax elements are coded as bitplanes in each picture header:

- Progressive I and BI picture headers in AP: ACPRED, OVERFLAGS
- Field interlace I and BI picture headers in AP: ACPRED, OVERFLAGS
- Frame interlace I and BI picture headers in AP: FIELDTX, ACPRED, OVERFLAGS
- Frame interlace P picture headers in AP: SKIPMB
- Progressive P picture headers in SP and MP: MVTYPEMB, SKIPMB
- Progressive P picture headers in AP: MVTYPEMB, SKIPMB
- Field interlace B picture headers in AP: FORWARDMB
- Frame interlace B picture headers in AP: DIRECTMB, SKIPMB
- Progressive B picture headers in AP: DIRECTMB, SKIPMB
- Progressive B picture headers in MP: DIRECTMB, SKIPMB

There are also seven different modes of coding the bitplane information. Except when the bitplane is coded in raw mode, the bitplane is decoded by the host and provided to the hardware in the bitplane buffer.

Since at most three bitplanes are encoded in any picture header, instead of using a complete byte for signaling the values of all the seven possible bitplanes for each MB, a more efficient approach is used with each byte divided in two nibbles and each nibble carries the data of up to four bitplanes for one MB.

PictureType	Bits 3, 7	Bit 2, 6	Bits 1, 5	Bits 0, 4
I or BI	0	OVERFLAGS	ACPRED	FIELDTX
P	0	MVTYPEMB	SKIPMB	0
B	0	FORWARDMB	SKIPMB	DIRECTMB

The bytes containing the above defined nibbles are stored in the bitplane buffer in raster scan order. The bitplane buffer is a linear buffer with a buffer pitch (as defined by Bitplane Buffer Pitch field in VC1_BSD_PIC_STATE command). When the number of macroblock in a row is odd, the last byte of the row containing the last macroblock in bits 0-3. The first macroblock of the next row starts at the next pitch offset from the first macroblock of the current row.

The bitplane buffer structure must be sent once per picture only if there is one or more syntax elements coded as bitplanes in the picture header.



Video Codecs

The following sections contain the various registers for video codec support. Specifically, the codec types supported are:

Supported Codec Types
Advanced Video Coding (AVC)/ H.264/MPEG-4 Part 10 (MVC)
MPEG-2 (H.222/H.262) — Used in Digital Video Broadcast and DVDs
VC1 — SMPTE 421M, known informally as VC-1
JPEG and MJPEG — A video format in which video gram or interlaced field of a digital video sequence is compressed separately as a JPEG image
Other Codec Functions



AVC (H.264)

AVC Common Commands

MFX Commands are organized into groups based on their scope of functioning. There are Pipeline Common state commands that are common to all codecs (encoder and decoder) and is applicable to the processing of one full frame/field. There are also individual codec Common state commands that are common to both encoder and decoder of that particular codec. These latter common state commands, some are applicable at the processing of one full frame/field, and some are applicable at the processing of an individual slice level.

MFX_AVC_IMG_STATE

MAX_QP_DELTA : Maximum QP delta is the Magnitude of QP delta between passes.

MAX_QP_DELTA is selected such that cumulative QP over all possible passes shouldn't exceed 51.

Example Configurations:

MAX Number of Passes	MAX_QP_DELTA
4	0xc
5	0xa
6	0x8
7	0x7

MFX_AVC_DIRECTMODE_STATE DevHSW:GT3:A, DevHSW:GT3:B, DevHSW:GT2:B

MFX_AVC_DIRECTMODE_STATE DevHSW, EXCLUDE(DevHSW:GT3:A, DevHSW:GT3:B, DevHSW:GT2:B)

MFX_AVC_SLICE_STATE

MFX_AVC_REF_IDX_STATE

MFX_AVC_WEIGHTOFFSET_STATE



AVC Decoder Commands

These are decoder-only commands. They provide the pointer to the compressed input bitstream to be decoded.

MFD_AVC_DPB_STATE

NOTE modified from DXVA2 – The values in RefFrameList and UsedForReference_Flag are the primary means by which the H/W can determine whether the corresponding entries in RefFrameList, POCList, LTSTFrameNumList, and Non-ExistingFrame_Flag should be considered valid for use in the decoding process of the current picture or not. When RefFrameList[i] is marked to be invalid, the values of POCList[i][0], POCList[i][1], LTSTFrameNumList[i], UsedForReference_Flag[i], and Non-ExistingFrame_Flag[i] must all be equal to 0. When UsedForReference_Flag[i] = 0, the value of RefFrameList[i] must be marked invalid.

MFD_AVC_SLICEADDR

MFD_AVC_BSD_OBJECT

Inline Data Description for MFD_AVC_BSD_Object

MFD_AVC_PICID_STATE

NOTE 1: In AVC short format, PictureIDList has one-to-one corresponding to LongTermFrame_Flag list, Non-ExistingFrame_flag list, UsedForReference_Flag list, FrameNumList list in MFD_AVC_DPB_STATE.

NOTE 2: PictureIDList is only used to identify reference picture across frames. Hardware will convert the picture in the RefFrameList to PictureID before writing out DMV data and convert back to RefFrameList Index after reading out DMV data. The reference pictures and their orders in the RefFrameList can be changed across frames.

Session Decoder StreamOut Data Structure

When StreamOut is enabled, per MB intermediated decoded data (MVs, mb_type, MB qp, etc.) are sent to the memory in a fixed record format (and of fixed size). The per-MB records must be written in a strict raster order and with no gap (i.e. every MB regardless of its mb_type and slice type, must have an entry in the StreamOut buffer). Therefore, the consumer of the StreamOut data can offset into the StreamOut Buffer (**StreamOut Data Destination Base Address**) using individual MB addresses.

A StreamOut Data record format is detailed as follows:

DWord	Bit	Description
0	23	Reserved MBZ
	22-20	EdgeFilterFlag (AVC) / OverlapSmoothFilter (VC1)
	19:17	CodedPatternDC (for AVC only, 111b for others) The field indicates whether DC coefficients are sent..



DWord	Bit	Description
		1 bit each for Y, U and V.
	16	Reserved MBZ
	15	<p>Transform8x8Flag</p> <p>When it is set to 0, the current MB uses 4x4 transform. When it is set to 1, the current MB uses 8x8 transform. The transform_size_8x8_flag syntax element, if present in the output bitstream, is the same as this field. However, whether transform_size_8x8_flag is present or not in the output bitstream depends on several conditions:</p> <p>This field is only allowed to be set to 1 for two conditions:</p> <ul style="list-style-type: none"> It must be 1 if IntraMbFlag = INTRA and IntraMbMode = INTRA_8x8 It may be 1 if IntraMbFlag = INTER and there is no sub partition size less than 8x8 <p>Otherwise, this field must be set to 0.</p> <p>0: 4x4 integer transform</p> <p style="text-align: center;">1: 8x8 integer transform</p>
	14	<p>MbFieldFlag</p> <p>This field specifies whether current macroblock is coded as a field or frame macroblock in MBAFF mode.</p> <p>This field is exactly the same as FIELD_PIC_FLAG syntax element in non-MBAFF mode.</p> <p>Same as the mb_field_decoding_flag syntax element in AVC spec.</p> <p>0 = Frame macroblock 1 = Field macroblock</p>
	13	<p>IntraMbFlag</p> <p>This field specifies whether the current macroblock is an Intra (I) macroblock.</p> <p>I_PCM is considered as Intra MB.</p> <p>For I-picture MB (IntraPicFlag =1), this field must be set to 1.</p> <p>This flag must be set in consistent with the interpretation of MbType (inter or intra modes).</p> <p>0: INTER (inter macroblock)</p> <p style="text-align: center;">1: INTRA (intra macroblock)</p>
	12:8	<p>MbType5Bits</p> <p>This field is encoded to match with the best macroblock mode determined as described in the next section. It follows AVC encoding for inter and intra macroblocks.</p>
	7	MbPolarity FieldMB Polarity - vctrl_vld_top_field AVC
	6	Reserved MBZ



DWord	Bit	Description
	5:4	<p>IntraMbMode</p> <p>This field is provided to carry information partially overlapped with MbType.</p> <p>This field is only valid if IntraMbFlag = INTRA, otherwise, it is ignored by hardware..</p>
	3	<p>Reserved MBZ</p>
	2	<p>MbSkipFlag</p> <p>Reserved MBZ (DXVA Encoder). HW (VDSunit) doesn't have skip MB info.</p> <p>It sets to 1 if any of the sub-blocks is inter, uses predicted MVs, and skips sending MVs explicitly in the code stream. Currently H/W can provide this flag and is defaulted to 0 always.</p>
	1:0	<p>InterMbMode</p> <p>This field is provided to carry redundant information as that in MbType. It also carries additional information such as skip.</p> <p>This field is only valid if IntraMbFlag =INTER, otherwise, it is ignored by hardware.</p>
1	31:16	<p>MbYCnt (Vertical Origin). This field specifies the vertical origin of current macroblock in the destination picture in units of macroblocks.</p> <p>Format = U8 in unit of macroblock.</p>
	15:0	<p>MbXCnt (Horizontal Origin). This field specifies the horizontal origin of current macroblock in the destination picture in units of macroblocks.</p> <p>Format = U8 in unit of macroblock.</p>
2	31	<p>Conceal MB Flag. This field specifies if the current MB is a conceal MB, use in AVC/VC1/MPEG2 mode</p>
	30	<p>Last MB of the Slice Flag. This field indicate the current MB is a last MB of the slice. Use in AVC/VC1/MPEG2 mode.</p>
	29:24	<p>Reserved</p>
	23:20	<p>CbpAcV</p> <p>0 in a bit – indicates the corresponding 8x8 block or 4x4 sub-block is not present (because all coefficient values are zero)</p> <p>1 in a bit – indicates the corresponding 8x8 block or 4x4 sub-block is present (although it is still possible to have all its coefficients be zero – bad coding).</p>



DWord	Bit	Description
	19:16	<p>CbpAcU</p> <p>0 in a bit – indicates the corresponding 8x8 block or 4x4 sub-block is not present (because all coefficient values are zero)</p> <p>1 in a bit – indicates the corresponding 8x8 block or 4x4 sub-block is present (although it is still possible to have all its coefficients be zero – bad coding).</p>
	15:0	<p>CbpAcY</p> <p>0 in a bit – indicates the corresponding 8x8 block or 4x4 sub-block is not present (because all coefficient values are zero)</p> <p>1 in a bit – indicates the corresponding 8x8 block or 4x4 sub-block is present (although it is still possible to have all its coefficients be zero – bad coding).</p> <p>Bit15=Y0Sub0, Bit0=Y3Sub3</p>
3	31:28	<p>Skip8x8Pattern (AVC)</p> <p>AVC This field indicates whether each of the four 8x8 sub macroblocks is using the predicted MVs and will not be explicitly coded in the bitstream (the sub macroblock will be coded as direct mode). It contains four 1-bit subfields, corresponding to the 4 sub macroblocks in sequential order. The whole macroblock may be actually coded as B_Direct_16x16 or B_Skip, according to the macroblock type conversion rules described in a later sub section.</p> <p>This field is only valid for a B slice. It is ignored by hardware for a P slice. Hardware also ignores this field for an intra macroblock.</p> <p>0 in a bit – Corresponding MVs are sent in the bitstream</p> <p>1 in a bit – Corresponding MVs are not sent in the bitstream</p>
	27:25	Reserved
	24:16	<p>NzCoefCountMB</p> <p>– all coded coefficients input including AC/DC blocks in current MB.</p> <p>Range 0 to 384 (9 bits)</p>
	15:8	MbClock16 – MB compute clocks in 16-clock unit.
	7	mbz (AVC) / QScaleType (MPEG2)
	6:0	<p>QpPrimeY (AVC) / QScaleCode (MPEG2)</p> <p>The luma quantization index. This is the per-MB QP value specified for the current MB.</p>
4 to 6	31:0 Each	<p>For intra macroblocks, definition of these fields are specified in 1</p> <p>For inter macroblocks, definition of these fields are specified in 2</p>



DWord	Bit	Description
7	31:24	Reserved
	23:20	MvFieldSelect (Ref polarity top or bottom bits) for VC1 and MPEG2 vcp_vds_mvdataR[162:159] VC1 vmd_vds_mt_vert_fld_selR[3:0] MPEG2
	19:12	Reserved
	11:10	SubBlockCodeType V (If 8x8, 8x4, 4x8, 4x4 type)
	9:8	SubBlockCodeType U (specifies 8x8, 8x4, 4x8, 4x4 type) VC1
	7:6	SubBlockCodeType Y3 (specifies 8x8, 8x4, 4x8, 4x4 type) VC1
	5:4	SubBlockCodeType Y2 (specifies 8x8, 8x4, 4x8, 4x4 type) VC1
	3:2	SubBlockCodeType Y1 (specifies 8x8, 8x4, 4x8, 4x4 type) VC1
	1:0	SubBlockCodeType Y0 (specifies 8x8, 8x4, 4x8, 4x4 type) VC1
Inter cases		
8	31:16	MvFwd[0].y – y-component of the forward motion vector of the 1 st 8x8 or 1 st 4x4 subblock
	15:0	MvFwd[0].x – x-component of the forward motion vector of the 1 st 8x8 or 1 st 4x4 subblock
9	31:0	MvBck[0] – the backward motion vector of the 1 st 8x8 or 1 st 4x4 subblock
10	31:0	MvFwd[1] – the forward motion vector of the 2 nd 8x8 or 4 th 4x4 subblock
11	31:0	MvBck[1] – the backward motion vector of the 2 nd 8x8 or 4 th 4x4 subblock
12	31:0	MvFwd[2] – the forward motion vector of the 3 rd 8x8 or 8 th 4x4 subblock
13	31:0	MvBck[2] – the backward motion vector of the 3 rd 8x8 or 8 th 4x4 subblock
14	31:0	MvFwd[3] – the forward motion vector of the 4 th 8x8 or 12 th 4x4 subblock
15	31:0	MvBck[3] – the backward motion vector of the 4 th 8x8 or 12 th 4x4 subblock
Intra Cases :		
8 to 15	31:0	Reserved MBZ



The inline data content of Dwords 4 to 6 is defined either for intra prediction or for inter prediction, but not both.

Inline data subfields for an Intra Macroblock

DWord	Bit	Description
4	31:16	<p>LumaIndraPredModes[1]</p> <p>Specifies the Luma Intra Prediction mode for four 4x4 sub-block of a MB, 4-bit each.</p> <p>AVC : See the bit assignment table later in this section.</p> <p>VC1 : MBZ.</p> <p>MPEG2 : MBZ.</p>
	15:0	<p>LumaIndraPredModes[0]</p> <p>Specifies the Luma Intra Prediction mode for four 4x4 sub-block, four 8x8 block or one intra16x16 of a MB.</p> <p>4-bit per 4x4 sub-block (Transform8x8Flag=0, Mbtype=0 and intraMbFlag=1) or 8x8 block (Transform8x8Flag=1, Mbtype=0, MbFlag=1), since there are 9 intra modes.</p> <p>4-bit for intra16x16 MB (Transform8x8Flag=0, Mbtype=1 to 24 and intraMbFlag=1), but only the LsBit[1:0] is valid, since there are only 4 intra modes.</p> <p>AVC : See the bit assignment table later in this section.</p> <p>VC1 : MBZ.</p> <p>MPEG2 : MBZ.</p>
5 AVC INTRA	31:16	<p>LumaIndraPredModes[3]</p> <p>Specifies the Luma Intra Prediction mode for four 4x4 sub-block of a MB, 4-bit each.</p> <p>AVC : See the bit assignment table later in this section.</p> <p>VC1 : MBZ.</p> <p>MPEG2 : MBZ.</p>
	15:0	<p>LumaIndraPredModes[2]</p> <p>Specifies the Luma Intra Prediction mode for four 4x4 sub-block of a MB, 4-bit each.</p> <p>AVC : See the bit assignment later in this section.</p> <p>VC1 : MBZ.</p> <p>MPEG2 : MBZ.</p>
6	31:8	Reserved (Reserved for encoder turbo mode IntraResidueDataSize , when this is not 0, optional residue data are provided to the PAK; Reserved for decoder)



DWord	Bit	Description																
	7:0	<p>MbIntraStruct</p> <p>The IntraPredAvailFlags[4:0] have already included the effect of the constrained_intra_pred_flag. See the diagram later for the definition of neighbors position around the current MB or MB pair (in MBAFF mode).</p> <p>1 – IntraPredAvailFlagX, indicates the values of samples of neighbor X can be used in intra prediction for the current MB.</p> <p>0 – IntraPredAvailFlagX, indicates the values of samples of neighbor X is not available for intra prediction of the current MB.</p> <p>IntraPredAvailFlag-A and -E can only be different from each other when constrained_intra_pred_flag is equal to 1 and mb_field_decoding_flag is equal to 1 and the value of the mb_field_decoding_flag for the macroblock pair to the left of the current macroblock is equal to 0 (which can only occur when MbaffFrameFlag is equal to 1).</p> <p>IntraPredAvailFlag-F is used only if</p> <ul style="list-style-type: none"> ○ it is in MBAFF mode, i.e. MbaffFrameFlag = 1, ○ the current macroblock is of frame type, i.e. MbFieldFag = 0, and ○ the current macroblock type is Intra8x8, i.e. IntraMbFlag = INTRA, IntraMbMode = INTRA_8x8, and Transform8x8Flag = 1. <p>In any other cases IntraPredAvailFlag-A shall be used instead.</p> <table border="1" style="width: 100%; border-collapse: collapse;"> <thead> <tr> <th style="width: 10%;">Bits</th> <th style="width: 90%;">IntraPredAvailFlags[4:0] Definition</th> </tr> </thead> <tbody> <tr> <td style="text-align: center;">7</td> <td>IntraPredAvailFlagF – F (Left 8th row (-1,7) neighbor)</td> </tr> <tr> <td style="text-align: center;">6</td> <td>IntraPredAvailFlagA – A (Left neighbor top half)</td> </tr> <tr> <td style="text-align: center;">5</td> <td>IntraPredAvailFlagE – E (Left neighbor bottom half)</td> </tr> <tr> <td style="text-align: center;">4</td> <td>IntraPredAvailFlagB – B (Top neighbor)</td> </tr> <tr> <td style="text-align: center;">3</td> <td>IntraPredAvailFlagC – C (Top right neighbor)</td> </tr> <tr> <td style="text-align: center;">2</td> <td>IntraPredAvailFlagD – D (Top left corner neighbor)</td> </tr> <tr> <td style="text-align: center;">1:0</td> <td>ChromaIntraPredMode – 2 bits to specify 1 of 4 chroma intra prediction mode, see the table in later section.</td> </tr> </tbody> </table>	Bits	IntraPredAvailFlags[4:0] Definition	7	IntraPredAvailFlagF – F (Left 8 th row (-1,7) neighbor)	6	IntraPredAvailFlagA – A (Left neighbor top half)	5	IntraPredAvailFlagE – E (Left neighbor bottom half)	4	IntraPredAvailFlagB – B (Top neighbor)	3	IntraPredAvailFlagC – C (Top right neighbor)	2	IntraPredAvailFlagD – D (Top left corner neighbor)	1:0	ChromaIntraPredMode – 2 bits to specify 1 of 4 chroma intra prediction mode, see the table in later section.
Bits	IntraPredAvailFlags[4:0] Definition																	
7	IntraPredAvailFlagF – F (Left 8 th row (-1,7) neighbor)																	
6	IntraPredAvailFlagA – A (Left neighbor top half)																	
5	IntraPredAvailFlagE – E (Left neighbor bottom half)																	
4	IntraPredAvailFlagB – B (Top neighbor)																	
3	IntraPredAvailFlagC – C (Top right neighbor)																	
2	IntraPredAvailFlagD – D (Top left corner neighbor)																	
1:0	ChromaIntraPredMode – 2 bits to specify 1 of 4 chroma intra prediction mode, see the table in later section.																	



Inline data subfields for an Inter Macroblock

DWord	Bit	Description
4	31:24	Reserved: MBZ (DXVA Decoder)
	23:16	Reserved: MBZ (DXVA Decoder)
	15:8	<p>SubMbPredModes[bit 7:0] (Sub Macroblock Prediction Mode)</p> <p>This field describes the prediction mode of the sub macroblocks (four 8x8 blocks). It contains four subfields each with 2-bits, corresponding to the 4 fixed size 8x8 sub macroblocks in sequential order.</p> <p>This field is provided for MB with sub_mb_type equal to BP_8x8 only (B_8x8 and P_8x8 as defined in DXVA)</p> <p>This field is derived from MbType for a non-BP_8x8 inter macroblock, and carries redundant information as MbType)</p> <p>Bits [1:0]: SubMbPredMode[0] – for 8x8 Block 0</p> <p>Bits [3:2]: SubMbPredMode[1] – for 8x8 Block 1</p> <p>Bits [5:4]: SubMbPredMode[2] – for 8x8 Block 2</p> <p>Bits [7:6]: SubMbPredMode[3] – for 8x8 Block 3</p> <p>Blocks of the MB is numbered as follows :</p> <pre> 0 1 2 3 </pre> <p>Each 2-bit value [1:0] is defined as :</p> <p>00 – Pred_L0</p> <p>01 – Pred_L1</p> <p>10 – BiPred</p> <p>For VC1:</p> <p>Bits [1:0]: "00"= Y0 Forward only, "01"= Y0 Backward only, "10"= Y0 Bi direction</p> <p>Bits [3:2]: SubMbPredMode[1] – for 8x8 Block 1</p> <p>Bits [5:4]: SubMbPredMode[2] – for 8x8 Block 2</p> <p>Bits [7:6]: SubMbPredMode[3] – for 8x8 Block 3</p>



DWord	Bit	Description
	7:0	<p>SubMbShape[bit 7:0] (Sub Macroblock Shape)</p> <p>This field describes the sub-block partitioning of each sub macroblocks (four 8x8 blocks). It contains four subfields each with 2-bits, corresponding to the 4 fixed size 8x8 sub macroblocks in sequential order.</p> <p>This field is provided for MB with sub_mb_type equal to BP_8x8 only (B_8x8 and P_8x8 as defined in DXVA)</p> <p>This field is forced to 0 for a non-BP_8x8 inter macroblock, and effectively carries redundant information as MbType).</p> <p>Bits [1:0]: SubMbShape[0] – for 8x8 Block 0 Bits [3:2]: SubMbShape[1] – for 8x8 Block 1 Bits [5:4]: SubMbShape[2] – for 8x8 Block 2 Bits [7:6]: SubMbShape[3] – for 8x8 Block 3</p> <p>Blocks of the MB is numbered as follows :</p> <pre> 0 1 2 3 </pre> <p>Each 2-bit value [1:0] is defined as :</p> <p>00 – SubMbPartWidth=8, SubMbPartHeight=8 01 – SubMbPartWidth=8, SubMbPartHeight=4 10 – SubMbPartWidth=4, SubMbPartHeight=8 11 – SubMbPartWidth=4, SubMbPartHeight=4</p> <p>For VC-1, This field indicates the transformation types used for luma components, 2 bits for each 8x8.</p>
5	31:24	<p>Frame Store ID L0[3]</p> <p>Support up to 4 Frame store ID per L0 direction, one per MB partition, if exists. See details in later section. This field specifies the frame Store ID into the Reference Picture List0 Table.</p> <p>Bit 7: Must Be One: (This is reserved for control fields in future extension, when reference index are generated instead of frame store ID)</p> <p>1: indicate it is in Frame store ID format. 0: indicate it is in Reference Index format.</p> <p>Bit 6:5: reserved MBZ</p> <p>Bit 4:0 : Frame store index or Frame Store ID (Bit 4:1 is used to form the binding table index in intel implementation)</p>



DWord	Bit	Description
	23:16	<p>Frame Store ID L0[2]</p> <p>Support up to 4 Frame store ID per L0 direction, one per MB partition, if exists. See details in later section. This field specifies the frame Store ID into the Reference Picture List0 Table.</p> <p>Bit 7: Must Be One: (This is reserved for control fields in future extension, when reference index are generated instead of frame store ID)</p> <p>1: indicate it is in Frame store ID format.</p> <p>0: indicate it is in Reference Index format.</p> <p>Bit 6:5: reserved MBZ</p> <p>Bit 4:0 : Frame store index or Frame Store ID (Bit 4:1 is used to form the binding table index in intel implementation)</p>
	15:8	<p>Frame Store ID L0[1]</p> <p>Support up to 4 Frame store ID per L0 direction, one per MB partition, if exists. See details in later section. This field specifies the frame Store ID into the Reference Picture List0 Table.</p> <p>Bit 7: Must Be One: (This is reserved for control fields in future extension, when reference index are generated instead of frame store ID)</p> <p>1: indicate it is in Frame store ID format.</p> <p>0: indicate it is in Reference Index format.</p> <p>Bit 6:5: reserved MBZ</p> <p>Bit 4:0 : Frame store index or Frame Store ID (Bit 4:1 is used to form the binding table index in intel implementation).</p>
	7:0	<p>Frame Store ID L0[0]</p> <p>Support up to 4 Frame store ID per L0 direction, one per MB partition, if exists. See details in later section. This field specifies the frame Store ID into the Reference Picture List0 Table.</p> <p>Bit 7: Must Be One: (This is reserved for control fields in future extension, when reference index are generated instead of frame store ID)</p> <p>1: indicate it is in Frame store ID format.</p> <p>0: indicate it is in Reference Index format.</p> <p>Bit 6:5: reserved MBZ</p> <p>Bit 4:0 : Frame store index or Frame Store ID (Bit 4:1 is used to form the binding table index in intel implementation)</p>



DWord	Bit	Description
6	31:24	<p>Frame Store ID L1[3]</p> <p>Support up to 4 Frame store ID per L0 direction, one per MB partition, if exists. See details in later section. This field specifies the frame Store ID into the Reference Picture List0 Table.</p> <p>Bit 7: Must Be One: (This is reserved for control fields in future extension, when reference index are generated instead of frame store ID)</p> <p>1: indicate it is in Frame store ID format.</p> <p>0: indicate it is in Reference Index format.</p> <p>Bit 6:5: reserved MBZ</p> <p>Bit 4:0 : Frame store index or Frame Store ID (Bit 4:1 is used to form the binding table index in intel implementation)</p>
	23:16	<p>Frame Store ID L1[2]</p> <p>Support up to 4 Frame store ID per L0 direction, one per MB partition, if exists. See details in later section. This field specifies the frame Store ID into the Reference Picture List0 Table.</p> <p>Bit 7: Must Be One: (This is reserved for control fields in future extension, when reference index are generated instead of frame store ID)</p> <p>1: indicate it is in Frame store ID format.</p> <p>0: indicate it is in Reference Index format.</p> <p>Bit 6:5: reserved MBZ</p> <p>Bit 4:0 : Frame store index or Frame Store ID (Bit 4:1 is used to form the binding table index in intel implementation)</p>
	15:8	<p>Frame Store ID L1[1]</p> <p>Support up to 4 Frame store ID per L0 direction, one per MB partition, if exists. See details in later section. This field specifies the frame Store ID into the Reference Picture List0 Table.</p> <p>Bit 7: Must Be One: (This is reserved for control fields in future extension, when reference index are generated instead of frame store ID)</p> <p>1: indicate it is in Frame store ID format.</p> <p>0: indicate it is in Reference Index format.</p> <p>Bit 6:5: reserved MBZ</p> <p>Bit 4:0 : Frame store index or Frame Store ID (Bit 4:1 is used to form the binding table index in intel implementation)</p>



DWord	Bit	Description
	7:0	<p>Frame Store ID L1[0]</p> <p>Support up to 4 Frame store ID per L0 direction, one per MB partition, if exists. See details in later section. This field specifies the frame Store ID into the Reference Picture List0 Table.</p> <p>Bit 7: Must Be One: (This is reserved for control fields in future extension, when reference index are generated instead of frame store ID)</p> <p>1: indicate it is in Frame store ID format.</p> <p>0: indicate it is in Reference Index format.</p> <p>Bit 6:5: reserved MBZ</p> <p>Bit 4:0 : Frame store index or Frame Store ID (Bit 4:1 is used to form the binding table index in intel implementation)</p>



AVC Encoder PAK Commands

Each PAK Commands is composed of a command op-code DW and one or more command data DWs (inline data). The size of each command is specified as part of the op-code DW. Most of the commands have fixed size, except some are allowed to be of variable length.

There is an inherent order of executing MFC PAK commands that driver must follow.

MFC_AVC_PAK_OBJECT

PAK Object Inline Data Description

The Inline Data includes all the required MB encoding states, constitute part of the Slice Data syntax elements, MB Header syntax elements and their derivatives. It provides information for the following operations:

1. Forward and Inverse Transform
2. Forward and Inverse Quantization
3. Advanced Rate Control (QRC)
4. MB Parameter Construction (MPC)
5. CABAC/CAVLC encoding
6. Bit stream packing
7. Intra and inter-Prediction decoding loop
8. Internal error handling

These state/parameter values may subject to change on a per-MB basis, and must be provided in each MFC_AVC_PAK_OBJECT command. The values set for these variables are retained internally, until they are reset by hardware Asynchronous Reset or changed by the next MFC_AVC_PAK_OBJECT command.

The inline data has been designed to match the DXVA 2.0, with the exception of the starting byte (DW0:0-7) and the ending dword (DW7:0-31).

The Deblocker Filter Control flags (FilterInternalEdgesFlag, FilterTopMbEdgeFlag and FilterLeftMbEdgesFlag) are generated by H/W, which are depending on MbaffFrameFlag, CurrMbAddr, PicWidthInMbs and disable_deblocking_filter_idc states.

Current MB [x,y] address is not sent, it is assumed that the H/W will keep track of the MB count and current MB position internally.



DWord	Bit	Description	Project
	30	Reserved: MBZ	
	23	Reserved : MBZ (reserved for future use as ExternalMvBufFlag)	
	19	CbpDcY. This field specifies if the Luma DC sub-block is coded. Setting it to 0 will force PAK to zero out the Luma sub-block. Otherwise, whether the sub-block is coded will be determined by the quantization process. 1 – the 4x4 DC-only Luma sub-block of the Intra16x16 coded MB is present; it is still possible that all DC coefficients are zero. 0 – no 4x4 DC-only Luma sub-block is present; either not in Intra16x16 MB mode or all DC coefficients are zero.	(HSW-ULT)
	18	CbpDcU. This field specifies if the Chroma Cb DC sub-block is coded. Setting it to 0 will force PAK to zero out the Luma sub-block. Otherwise, whether the sub-block is coded will be determined by the quantization process. 1 – the 2x2 DC-only Chroma Cb sub-block of all coded MB (any type) is present; it is still possible that all DC coefficients are zero. 0 – no 2x2 DC-only Chroma Cb sub-block is present; all DC coefficients are zero.	Exclude(HSW-ULT)
	17	CbpDcV. This field specifies if the Chroma Cb DC sub-block is coded. Setting it to 0 will force PAK to zero out the Luma sub-block. Otherwise, whether the sub-block is coded will be determined by the quantization process. 1 – the 2x2 DC-only Chroma Cr sub-block of all coded MB (any type) is present; it is still possible that all DC coefficients are zero. 0 – no 2x2 DC-only Chroma Cr sub-block is present; all DC coefficients are zero.	(HSW-ULT)
	16	Reserved: MBZ (reserved for future use as ExternalResidBufFlag for turbo mode)	
	15	Transform8x8Flag This field indicates that 8x8 transform is used for the macroblock. When it is set to 0, the current MB uses 4x4 transform. When it is set to 1, the current MB uses 8x8 transform. The transform_size_8x8_flag syntax element, if present in the output bitstream, is the same as this field. However, whether transform_szie_8x8_flag is present or not in the	



DWord	Bit	Description	Project
		<p>output bitstream depends on several other conditions.</p> <p>This field is only allowed to be set to 1 for two conditions:</p> <p>It must be 1 if IntraMbFlag = INTRA and IntraMbMode = INTRA_8x8</p> <p>It may be 1 if IntraMbFlag = INTER and there is no sub partition size less than 8x8</p> <p>Otherwise, this field must be set to 0.</p> <p>When SvcSliceState TcoeffLvlPredFlag=1, and AvcImgState EntropyCodingFlag is 1(CABAC), this field cannot be 1</p> <p>0: 4x4 integer transform 1: 8x8 integer transform</p>	
	14	<p>FieldMbFlag</p> <p>This field specifies the field polarity of the current macroblock, as the mb_field_decoding_flag syntax element in AVC spec.</p> <p>This field specifies whether current macroblock is coded as a field or frame macroblock in MBAFF mode. It is exactly the same as FIELD_PIC_FLAG syntax element in non-MBAFF mode.</p> <p>0 = Frame macroblock 1 = Field macroblock</p>	
	13	<p>IntraMbFlag</p> <p>This field specifies whether the current macroblock is an Intra (I) macroblock. I_PCM is considered as Intra MB.</p> <p>For I-picture MB (IntraPicFlag =1), this field must be set to 1.</p> <p>This flag must be set in consistent with the interpretation of MbType (inter or intra modes).</p> <p>0: INTER (inter macroblock) 1: INTRA (intra macroblock)</p>	
	12:8	<p>MbType5Bits</p> <p>This field is encoded to match with the best macroblock mode determined as described in the next section. It follows an unified encoding for inter and intra macroblocks according to AVC Spec.</p>	
	7	<p>FieldMbPolarityFlag</p> <p>This field indicates the field polarity of the current macroblock.</p> <p>Within an MbAff frame picture, this field may be different per macroblock and is set to 1 only for the second macroblock in a MbAff pair if FieldMbFlag is set. Otherwise, it is set to 0.</p> <p>Within a field picture, this field is set to 1 if the current picture is the</p>	



DWord	Bit	Description	Project
		<p>bottom field picture. Otherwise, it is set to 0. It is a constant for the whole field picture.</p> <p>This field is reserved and MBZ for a progressive frame picture.</p> <p>0 = Current macroblock is a field macroblock from the top field</p> <p>1 = Current macroblock is a field macroblock from the bottom field</p> <p><i>Programming Note: Here bits [26:24] (MbAffFieldFlag and FiedlMbPolarityFlag) match with bits [10:8] of the Media Block Read message descriptor, simplifying the programming for message generation, as when MbAffFieldFlag is "1", kernels need to override the original "frame" surface state set for MBAFF frame picture.</i></p>	
	6	<p>MB Reserved: Inter MB converted to IPCM</p> <p>This field is used for HW purpose only</p> <p>SW should not use it.</p>	
	5:4	<p>IntraMbMode</p> <p>This field is provided to carry information partially overlapped with MbType.</p> <p>This field is only valid if IntraMbFlag = INTRA, otherwise, it is ignored by hardware..</p>	
	3	Reserved: MBZ	
	2	<p>SkipMbFlag</p> <p>By setting it to 1, this field forces an inter macroblock to be encoded as a skipped macroblock. It is equivalent to mb_skip_flag in AVS spec, indicating that a macroblock is inferred as a P_Skip (or B_Skip) in a P Slice (or B Slice). Hardware honors input MVs for motion prediction and forces CBP to zero.</p> <p>By setting it to 0, an inter macroblock will be coded as a normal inter macroblock. The macroblock may still be coded as a skipped macroblock, according to the macroblock type conversion rules described in the later sub sections.</p> <p>This field can only be set to 1 for certain values of MbType. See details later.</p> <p>This field is only valid for an inter macroblock. For intra MB (bit 13 of this DW set to one), this bit must be set to zero.</p> <p>0 = not a skipped macroblock</p> <p>1 = is coded as a skipped macroblock</p>	
	1:0	<p>InterMbMode</p> <p>This field is provided to carry redundant information as that encoded in</p>	



DWord	Bit	Description	Project
		<p>MbType.</p> <p>This field is only valid if IntraMbFlag =0, otherwise, it is ignored by hardware.</p>	
4	31:16	<p>Cbp4x4Y[bit 15:0] (Coded Block Pattern Y)</p> <p>For 4x4 sub-block (when Transform8x8flag = 0 or in intra16x16) : 16-bit cbp, one bit for each 4x4 Luma sub-block (not including the DC 4x4 Luma block in intra16x16) in a MB. The 4x4 Luma sub-blocks are numbered as</p> <pre> blk0 1 4 5 bit15 14 11 10 lk2 3 6 7 bit13 12 9 8 blk8 9 12 13 bit7 6 3 2 blk10 11 14 15 bit5 4 1 0 </pre> <p>The cbpY bit assignment is cbpY bit [15 - X] for sub-block_num X.</p> <p>For 8x8 block (when Transform8x8flag = 1) Only the lower 4 bits [3:0] are valid; the remaining upper bits [15:4] are ignored. The 8x8 Luma blocks are numbered as</p> <pre> blk0 1 bit3 2 blk2 3 bit1 0 </pre> <p>The cbpY bit assignment is cbpY bit [3 - X] for block_num X.</p> <p>0 in a bit - indicates the corresponding 8x8 block or 4x4 sub-block is not present (because all coefficient values are zero), or force to zero for PAK.</p> <p>1 in a bit - indicates the corresponding 8x8 block or 4x4 sub-block is present (although it is still possible to have all its coefficients be zero - bad coding).</p>	(HSW-ULT)
	15:8	<p>MbYCnt (Vertical Origin). This field specifies the vertical origin of current macroblock in the destination picture in units of macroblocks. Format = U8 in unit of macroblock.</p>	
	7:0	<p>MbXCnt (Horizontal Origin). This field specifies the horizontal origin of current macroblock in the destination picture in units of macroblocks. Format = U8 in unit of macroblock.</p>	



DWord	Bit	Description	Project
6	31:28	<p>Skip8x8Pattern</p> <p>This field indicates whether each of the four 8x8 sub macroblocks is using the predicted MVs and will not be explicitly coded in the bitstream (the sub macroblock will be coded as direct mode). It contains four 1-bit subfields, corresponding to the 4 sub macroblocks in sequential order. The whole macroblock may be actually coded as B_Direct_16x16 or B_Skip, according to the macroblock type conversion rules described in a later sub section.</p> <p>This field is only valid for a B slice. It is ignored by hardware for a P slice. Hardware also ignores this field for an intra macroblock.</p> <p>0 in a bit – Corresponding MVs are sent in the bitstream 1 in a bit – Corresponding MVs are not sent in the bitstream</p>	
	27	<p>EnableCoeffClamp</p> <p>1 = the magnitude of coefficients of the current MB will be clamped based on the clamping matrix after quantization 0 = no clamping</p>	
	26	<p>LastMbFlag</p> <p>1 – the current MB is the last MB in the current Slice 0 – the current MB is not the last MB in the current SliceReserved MBZ.</p>	
	25	<p>SkipMbConvDisable</p> <p>This is a per-MB level control to enable and disable skip conversion. This field is ORed with SkipConvDisable field. This field is only valid for a P or B slice. It must be zero for other slice types. Rules are provided in Section <i>Macroblock Type Conversion Rules</i></p> <p>0 - Enable skip type conversion for the current macroblock 1 - Disable skip type conversion for the current macroblock</p>	
	24	Reserved MBZ.	HSW+
	23:16	<p>Reserved. Ignored by HW, this field will be re-derived internally.</p> <p>(was QpPrimeV. For 8-bit pixel data, QpCr is the same as QpPrimeCr, and it takes on a value in the range of 0 to 51, positive integer.)</p>	HSW+
	15:8	<p>Reserved. Ignored by HW, this field will be re-derived internally.</p> <p>(Was QpPrimeU. For 8-bit pixel data, QpCb is the same as QpPrimeCb, and it takes on a value in the range of 0 to 51, positive integer.)</p>	HSW+
	7:0	<p>QpPrimeY</p> <p>This is the per-MB QP value specified for the current MB.</p>	



DWord	Bit	Description	Project
		For 8-bit pixel data, QpY is the same as QpPrimeY, and it takes on a value in the range of 0 to 51, positive integer. Note: This value may differ from the actual codes, when HW QRC is on	
7..9	31:0 Each	For intra macroblocks, definition of these fields are specified in <i>PAK Object Inline Data Description</i> For inter macroblocks, definition of these fields are specified in <i>PAK Object Inline Data Description</i>	
10	31:24	MaxSizeInWord PAK should not exceed this budget accumulatively, otherwise it will trickle the PANIC mode.	
	23:16	TargetSizeInWord PAK should use this budget accumulatively to decide if it needs to limit the number of non-zero coefficients.	
	15:0	Reserved:MBZ	

VDenc Mode Inline data (For PAK Standalone validation)

DWord	Bit	Description
12	31:16	Reserved
	15:0	Reserved
13	31:16	Reserved
	15:0	Reserved
14	31:16	Reserved
	15:0	Reserved
15	31:16	Reserved
	15:0	Reserved
16	31:16	Reserved
	15:0	Reserved
17	31:16	Reserved
	15:0	Reserved
18	31:16	Reserved
	15:0	Reserved
19	31:16	Reserved
	15:0	Reserved



DWord	Bit	Description
20	31:16	LumaIntraMode[1] Specifies the Luma Intra Prediction mode for four 4x4 sub-block of a MB, 4-bit each.
	15:0	LumaIntraMode[0] Specifies the Luma Intra Prediction mode for four 4x4 sub-block, four 8x8 block or one intra16x16 of a MB. 4-bit per 4x4 sub-block (Transform8x8Flag=0, Mbtype=0 and intraMbFlag=1) or 8x8 block (Transform8x8Flag=1, Mbtype=0, MbFlag=1), since there are 9 intra modes. 4-bit for intra16x16 MB (Transform8x8Flag=0, Mbtype=1 to 24 and intraMbFlag=1), but only the LBit[1:0] is valid, since there are only 4 intra modes.
21	31:16	LumaIntraMode[3] Specifies the Luma Intra Prediction mode for four 4x4 sub-block of a MB, 4-bit each.
	15:0	LumaIntraMode[2] Specifies the Luma Intra Prediction mode for four 4x4 sub-block of a MB, 4-bit each.
22	31:16	Minimal Distortion This field contains the overall distortion for the source block associated with the winning MbType, which could be one of intra or inter modes.
	15:0	SkipRawDistortion This field contains Skip Raw Distortion which may be used by software to further refine the skip decision.
23	31:16	InterRawDistortion This field provides the Inter Raw Distortion (Sad/Haar) for the current macroblock.
	15:0	BestIntraRawDistortion This field contains the best IntraRawDistortion (Sad/Haar) for the current macroblock. The IntraMBMode will indicate if this is a16x16/8x8/4x4 distortion.



Inline data for LumaIntraMode

ExtendedForm	0 or 1	0	0	1	1
	Intra4x4	Intra8x8	Intra16x16	Intra8x8	Intra16x16
DW4 – 31:28	Block 7	-	-	-	Block 0
DW4 – 27:24	Block 6	-	-	-	Block 0
DW4 – 23:20	Block 5	-	-	-	Block 0
DW4 – 19:16	Block 4	-	-	-	Block 0
DW4 – 15:12	Block 3	-	-	-	Block 0
DW4 – 11:8	Block 2	-	-	-	Block 0
DW4 – 7:4	Block 1	-	-	-	Block 0
DW4 – 3:0	Block 0	-	-	-	Block 0
DW5 – 31:28	Block 15	-	-	-	Block 0
DW5 – 27:24	Block 14	-	-	-	Block 0
DW5 – 23:20	Block 13	-	-	-	Block 0
DW5 – 19:16	Block 12	-	-	-	Block 0
DW5 – 15:12	Block 11	-	-	-	Block 0
DW5 – 11:8	Block 10	-	-	-	Block 0
DW5 – 7:4	Block 9	-	-	-	Block 0
DW5 – 3:0	Block 8	-	-	-	Block 0



vctrl_pred_mode[63:0]	(vctrl_it_lumaintrapredmode3[15:0] & vctrl_it_lumaintrapredmode2[15:0] & vctrl_it_lumaintrapredmode1[15:0] & vctrl_it_lumaintrapredmode0[15:0]) : vctrl_pred_mode_noextend[63:0]
vctrl_pred_mode_noextend[63:0]	(vctrl_INTRA_vld_16x16mode & vctrl_it_Transform8x8Flag) ? vctrl_pred_mode_noextend_4x4[63:0] : vctrl_pred_mode_noextend_16x16[63:0] : vctrl_pred_mode_noextend_8x8[63:0] : vctrl_pred_mode_noextend_4x4[63:0]
vctrl_pred_mode_noextend_16x16[63:0]	vctrl_it_lumaintrapredmode0[3:0] & vctrl_it_lumaintrapredmode0[3:0] & vctrl_it_lumaintrapredmode0[3:0] & vctrl_it_lumaintrapredmode0[3:0] & vctrl_it_lumaintrapredmode0[3:0] & vctrl_it_lumaintrapredmode0[3:0] & vctrl_it_lumaintrapredmode0[3:0] & vctrl_it_lumaintrapredmode0[3:0] & vctrl_it_lumaintrapredmode0[3:0] & vctrl_it_lumaintrapredmode0[3:0] & vctrl_it_lumaintrapredmode0[3:0] & vctrl_it_lumaintrapredmode0[3:0] & vctrl_it_lumaintrapredmode0[3:0] & vctrl_it_lumaintrapredmode0[3:0] & vctrl_it_lumaintrapredmode0[3:0] & vctrl_it_lumaintrapredmode0[3:0]
vctrl_pred_mode_noextend_8x8[63:0]	"h000" & vctrl_it_lumaintrapredmode0[15:12] & "h000" & vctrl_it_lumaintrapredmode0[11:8] & "h000" & vctrl_it_lumaintrapredmode0[7:4] & "h000" & vctrl_it_lumaintrapredmode0[3:0]
vctrl_pred_mode_noextend_4x4[63:0]	vctrl_it_lumaintrapredmode3[15:0] & vctrl_it_lumaintrapredmode2[15:0] & vctrl_it_lumaintrapredmode1[15:0] & vctrl_it_lumaintrapredmode0[15:0]



Inline data for RefPicSelect

	0	0	0	0 or 1	1	1	1
ExtendedForm	16x16	16x8	8x16	8x8	16x16	16x8	8x16
DW8 – 31:24	-	-	-	L0 blk3	L0 blk0	-	L0 blk1
DW8 – 23:16	-	-	-	L0 blk2	L0 blk0	-	L0 blk0
DW8 – 15:8	-	L0 blk1	L0 blk1	L0 blk1	L0 blk0	-	L0 blk1
DW8 – 7:0	L0 blk0	L0 blk0	L0 blk0	L0 blk0	L0 blk0	-	L0 blk0
DW9 – 31:24	-	-	-	L1 blk3	L1 blk0	-	L1 blk1
DW9 – 23:16	-	-	-	L1 blk2	L1 blk0	-	L1 blk0
DW9 – 15:8	-	L1 blk1	L1 blk1	L1 blk1	L1 blk0	-	L1 blk1
DW9 – 7:0	L1 blk0	L1 blk0	L1 blk0	L1 blk0	L1 blk0	-	L1 blk0

The inline data content of Dwords 4 to 6 is defined either for intra prediction or for inter prediction, but not both.



Inline data subfields for an Intra Macroblock

Dword	Bit	Description
7	31:16	<p>LumaIntraMode[1]</p> <p>Specifies the Luma Intra Prediction mode for four 4x4 sub-block of a MB, 4-bit each.</p> <p>See the bit assignment table later in this section.</p>
	15:0	<p>LumaIntraMode[0]</p> <p>Specifies the Luma Intra Prediction mode for four 4x4 sub-block, four 8x8 block or one intra16x16 of a MB.</p> <p>4-bit per 4x4 sub-block (Transform8x8Flag=0, Mbtype=0 and intraMbFlag=1) or 8x8 block (Transform8x8Flag=1, Mbtype=0, MbFlag=1), since there are 9 intra modes.</p> <p>4-bit for intra16x16 MB (Transform8x8Flag=0, Mbtype=1 to 24 and intraMbFlag=1), but only the LBit[1:0] is valid, since there are only 4 intra modes.</p> <p>See the bit assignment table later in this section.</p>
8	31:16	<p>LumaIntraMode[3]</p> <p>Specifies the Luma Intra Prediction mode for four 4x4 sub-block of a MB, 4-bit each.</p> <p>See the bit assignment table later in this section.</p>
	15:0	<p>LumaIntraMode[2]</p> <p>Specifies the Luma Intra Prediction mode for four 4x4 sub-block of a MB, 4-bit each.</p> <p>See the bit assignment later in this section.</p>
9	31:8	<p>Reserved : MBZ</p> <p>(Reserved for encocder turbo mode IntraResidueDataSize, when this is not 0, optional residue data are provided to the PAK; Reserved for decoder)</p>
	7:0	<p>IntraStruct</p> <p>This field contains 6 bits for IntraPredAvailFlags[5:0] and 2 bits for ChromaIntraPredMode. The IntraPredAvailFlags[4:0] (the lower 5 bits) have already included the effect of the constrained_intra_pred_flag. See the diagram later for the definition of neighbor position around the current MB or MB pair (in MBAFF mode).</p> <p>1 – IntraPredAvailFlagY, indicates the values of samples of neighbor Y can be used in intra prediction for the current MB.</p> <p>0 – IntraPredAvailFlagY, indicates the values of samples of neighbor Y is not available for intra prediction of the current MB.</p> <p>IntraPredAvailFlag-A and -E can only be different from each other when constrained_intra_pred_flag</p>



Dword	Bit	Description																
		<p>is equal to 1 and mb_field_decoding_flag is equal to 1 and the value of the mb_field_decoding_flag for the macroblock pair to the left of the current macroblock is equal to 0 (which can only occur when MbaffFrameFlag is equal to 1).</p> <p>IntraPredAvailFlag-F is used only if</p> <p>it is in MBAFF mode, i.e. MbaffFrameFlag = 1,</p> <p>the current macroblock is of frame type, i.e. MbFieldFag = 0, and</p> <p>the current macroblock type is Intra8x8, i.e. IntraMbFlag = INTRA, IntraMbMode = INTRA_8x8, and Transform8x8Flag = 1.</p> <p>In any other cases IntraPredAvailFlag-A shall be used instead.</p> <table border="1" data-bbox="321 739 1494 1358"> <thead> <tr> <th data-bbox="321 739 386 785">Bits</th> <th data-bbox="386 739 1494 785">IntraPredAvailFlags Definition</th> </tr> </thead> <tbody> <tr> <td data-bbox="321 785 386 861">7</td> <td data-bbox="386 785 1494 861">IntraPredAvailFlagF – F (Left 8th row (-1,7) neighbor)</td> </tr> <tr> <td data-bbox="321 861 386 936">6</td> <td data-bbox="386 861 1494 936">IntraPredAvailFlagA – A (Left neighbor top half)</td> </tr> <tr> <td data-bbox="321 936 386 1012">5</td> <td data-bbox="386 936 1494 1012">IntraPredAvailFlagE – E (Left neighbor bottom half)</td> </tr> <tr> <td data-bbox="321 1012 386 1087">4</td> <td data-bbox="386 1012 1494 1087">IntraPredAvailFlagB – B (Top neighbor)</td> </tr> <tr> <td data-bbox="321 1087 386 1163">3</td> <td data-bbox="386 1087 1494 1163">IntraPredAvailFlagC – C (Top right neighbor)</td> </tr> <tr> <td data-bbox="321 1163 386 1239">2</td> <td data-bbox="386 1163 1494 1239">IntraPredAvailFlagD – D (Top left corner neighbor)</td> </tr> <tr> <td data-bbox="321 1239 386 1358">1:0</td> <td data-bbox="386 1239 1494 1358">ChromaIntraPredMode – 2 bits to specify 1 of 4 chroma intra prediction modes, see the table in later section.</td> </tr> </tbody> </table>	Bits	IntraPredAvailFlags Definition	7	IntraPredAvailFlagF – F (Left 8 th row (-1,7) neighbor)	6	IntraPredAvailFlagA – A (Left neighbor top half)	5	IntraPredAvailFlagE – E (Left neighbor bottom half)	4	IntraPredAvailFlagB – B (Top neighbor)	3	IntraPredAvailFlagC – C (Top right neighbor)	2	IntraPredAvailFlagD – D (Top left corner neighbor)	1:0	ChromaIntraPredMode – 2 bits to specify 1 of 4 chroma intra prediction modes, see the table in later section.
Bits	IntraPredAvailFlags Definition																	
7	IntraPredAvailFlagF – F (Left 8 th row (-1,7) neighbor)																	
6	IntraPredAvailFlagA – A (Left neighbor top half)																	
5	IntraPredAvailFlagE – E (Left neighbor bottom half)																	
4	IntraPredAvailFlagB – B (Top neighbor)																	
3	IntraPredAvailFlagC – C (Top right neighbor)																	
2	IntraPredAvailFlagD – D (Top left corner neighbor)																	
1:0	ChromaIntraPredMode – 2 bits to specify 1 of 4 chroma intra prediction modes, see the table in later section.																	



Inline data subfields for an Inter Macroblock

DWord	Bit	Description
7	31:16	Reserved : MBZ
	15:8	<p>SubMbPredMode (Sub-Macroblock Prediction Mode): If InterMbMode is INTER8x8, this field describes the prediction mode of the sub-partitions in the four 8x8 sub-macroblock. It contains four subfields each with 2-bits, corresponding to the four 8x8 sub-macroblocks in sequential order.</p> <p>This field is derived from sub_mb_type for a BP_8x8 macroblock.</p> <p>This field is derived from MbType for a non-BP_8x8 inter macroblock, and carries redundant information as MbType).</p> <p>If InterMbMode is INTER16x16, INTER16x8 or INTER8x16, this field carries the prediction modes of the sub macroblock (one 16x16, two 16x8 or two 8x16). The unused bits are set to zero.</p> <p>Bits [1:0]: SubMbPredMode[0] Bits [3:2]: SubMbPredMode[1] Bits [5:4]: SubMbPredMode[2] Bits [7:6]: SubMbPredMode[3]</p>
	7:0	<p>SubMbShape (Sub Macroblock Shape)</p> <p>This field describes the sub-block partitioning of each sub macroblocks (four 8x8 blocks). It contains four subfields each with 2-bits, corresponding to the 4 fixed size 8x8 sub macroblocks in sequential order.</p> <p>This field is provided for MB with sub_mb_type equal to BP_8x8 only (B_8x8 and P_8x8 as defined in DXVA). Otherwise, this field is ignored by hardware</p> <p>Bits [1:0]: SubMbShape[0] – for 8x8 Block 0 Bits [3:2]: SubMbShape[1] – for 8x8 Block 1 Bits [5:4]: SubMbShape[2] – for 8x8 Block 2 Bits [7:6]: SubMbShape[3] – for 8x8 Block 3</p> <p>Blocks of the MB is numbered as follows :</p> <p>01 23</p> <p>Each 2-bit value [1:0] is defined as :</p> <p>00 – SubMbPartWidth=8, SubMbPartHeight=8 01 – SubMbPartWidth=8, SubMbPartHeight=4 10 – SubMbPartWidth=4, SubMbPartHeight=8 11 – SubMbPartWidth=4, SubMbPartHeight=4</p>



DWord	Bit	Description
8	31:24	RefPicSelect[0][3] Support up to 4 reference pictures per L0 direction, one per MB partition, if exists. See details in later section. This field specifies the reference index into the Reference Picture List0 Table.
	23:16	RefPicSelect[0][2] Support up to 4 reference pictures per L0 direction, one per MB partition, if exists. See details in later section. This field specifies the reference index into the Reference Picture List0 Table.
	15:8	RefPicSelect[0][1] Support up to 4 reference pictures per L0 direction, one per MB partition, if exists. See details in later section. This field specifies the reference index into the Reference Picture List0 Table.
	7:0	RefPicSelect[0][0] Support up to 4 reference pictures per L0 direction, one per MB partition, if exists. See details in later section. This field specifies the reference index into the Reference Picture List0 Table.
9	31:24	RefPicSelect[1][3] Support up to 4 reference pictures per L1 direction, one per MB partition, if exists. See details in later section. This field specifies the reference index into the Reference Picture List1 Table. For P- picture these bits must be set to zero.
	23:16	RefPicSelect[1][2] Support up to 4 reference pictures per L1 direction, one per MB partition, if exists. See details in later section. This field specifies the reference index into the Reference Picture List1 Table. For P- picture these bits must be set to zero.
	15:8	RefPicSelect[1][1] Support up to 4 reference pictures per L1 direction, one per MB partition, if exists. See details in later section. This field specifies the reference index into the Reference Picture List1 Table. For P- picture these bits must be set to zero.
	7:0	RefPicSelect[1][0] Support up to 4 reference pictures per L1 direction, one per MB partition, if exists. See details in later section. This field specifies the reference index into the Reference Picture List1 Table. For P- picture these bits must be set to zero.



Luma Intra Prediction Modes

Luma Intra Prediction Modes (LumaIntraPredModes) is defined in *Luma Intra Prediction Modes*. It is further categorized as Intra16x16PredMode (*Luma Intra Prediction Modes*), Intra8x8PredMode (*Luma Intra Prediction Modes*) and Intra4x4PredMode (*Luma Intra Prediction Modes*), operating on 16x16, 8x8 and 4x4 block sizes, respectively. illustrates the intra prediction directions geometrically for the Intra4x4 prediction. When a macroblock is subdivided, the intra prediction is performed for the subdivision in a predetermined order. For example, *Luma Intra Prediction Modes* shows the block order for Intra4x4 prediction. And *Luma Intra Prediction Modes* shows the block order of Block8x8 in a 16x16 region or Block4x4 in an 8x8 region.

Definition of LumaIntraPredModes

LumaIntraPredModes [index]		Intra16x16PredMode	Intra8x8PredMode	Intra4x4PredMode
Index	Bit	MbType = [1...24] Transform8x8Flag = 0	MbType = 0 Transform8x8Flag = 1	MbType = 0 Transform8x8Flag = 0
0	15:12	MBZ	Block8x8 3	Block4x4 3 (0_0)
	11:8	MBZ	Block8x8 2	Block4x4 2 (0_1)
	7:4	MBZ	Block8x8 1	Block4x4 1 (0_2)
	3:0	Block16x16	Block8x8 0	Block4x4 0 (0_3)
1	15:12	MBZ	MBZ	Block4x4 7 (1_0)
	11:8	MBZ	MBZ	Block4x4 6 (1_1)
	7:4	MBZ	MBZ	Block4x4 5 (1_2)
	3:0	MBZ	MBZ	Block4x4 4 (1_3)
2	15:12	MBZ	MBZ	Block4x4 11 (2_0)
	11:8	MBZ	MBZ	Block4x4 10 (2_1)
	7:4	MBZ	MBZ	Block4x4 9 (2_2)
	3:0	MBZ	MBZ	Block4x4 8 (2_3)



LumaIntraPredModes [index]		Intra16x16PredMode	Intra8x8PredMode	Intra4x4PredMode
Index	Bit	MbType = [1...24] Transform8x8Flag = 0	MbType = 0 Transform8x8Flag = 1	MbType = 0 Transform8x8Flag = 0
3	15:12	MBZ	MBZ	Block4x4 15 (3_0)
	11:8	MBZ	MBZ	Block4x4 14 (3_1)
	7:4	MBZ	MBZ	Block4x4 13 (3_2)
	3:0	MBZ	MBZ	Block4x4 12 (3_3)

Definition of Intra16x16PredMode

Intra16x16PredMode	Description
0	Intra_16x16_Vertical
1	Intra_16x16_Horizontal
2	Intra_16x16_DC
3	Intra_16x16_Plane
4 – 15	Reserved



Definition of Intra8x8PredMode

Intra8x8PredMode	Description
0	Intra_8x8_Vertical
1	Intra_8x8_Horizontal
2	Intra_8x8_DC
3	Intra_8x8_Diagonal_Down_Left
4	Intra_8x8_Diagonal_Down_Right
5	Intra_8x8_Vertical_Right
6	Intra_8x8_Horizontal_Down
7	Intra_8x8_Vertical_Left
8	Intra_8x8_Horizontal_Up
9 – 15	Reserved



Definition of Intra4x4PredMode

Intra4x4PredMode	Description
0	Intra_4x4_Vertical
1	Intra_4x4_Horizontal
2	Intra_4x4_DC
3	Intra_4x4_Diagonal_Down_Left
4	Intra_4x4_Diagonal_Down_Right
5	Intra_4x4_Vertical_Right
6	Intra_4x4_Horizontal_Down
7	Intra_4x4_Vertical_Left
8	Intra_4x4_Horizontal_Up
9 – 15	Reserved

Intra_4x4 prediction mode directions

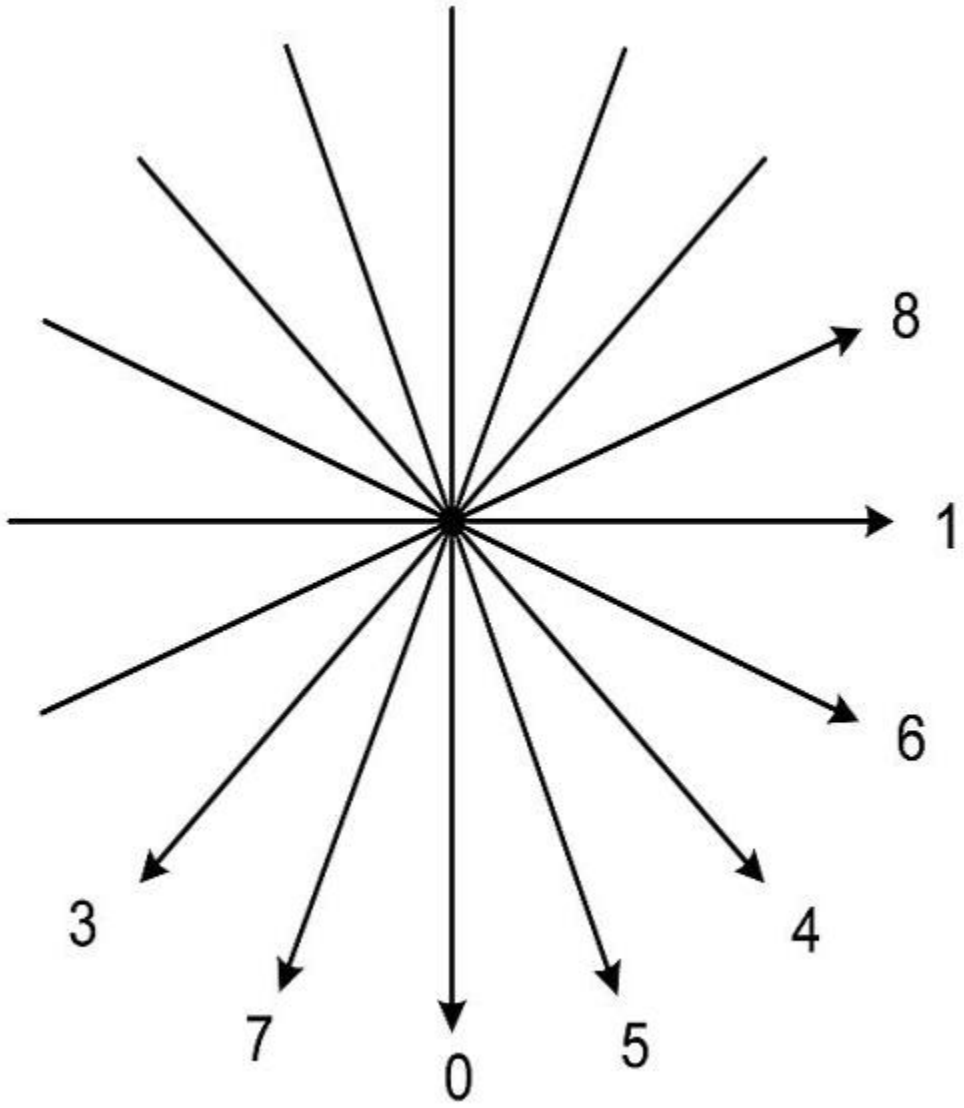



Numbers of Block4x4 in a 16x16 region

0	1	4	5
2	3	6	7
8	9	12	13
10	11	14	15

Numbers of Block4x4 in an 8x8 region or numbers of Block8x8 in a 16x16 region

0	1
2	3

Definition of Chroma Intra Prediction Mode

ChromaIntraPredMode (intra_chroma_pred_mode)	Name of intra_chroma_pred_mode
0	Intra_Chroma_DC (prediction mode)
1	Intra_Chroma_Horizontal (prediction mode)
2	Intra_Chroma_Vertical (prediction mode)
3	Intra_Chroma_Plane (prediction mode)



Reference Indices Defined for Each MB Partition Type and Bit Assignment

MB partitioning	frame/field MB/Picture				
	16x16	16x8	8x16	8x8	
RefIdxL0/1[0]	blk0	blk0	blk0	blk0	Bit 7:0
RefIdxL0/1[1]	x	blk1	blk1	blk1	Bit 15:8
RefIdxL0/1[2]	x	x	x	blk2	Bit 23:16
RefIdxL0/1[3]	x	x	x	blk3	Bit 31:24

MB Neighbor Availability in Intra-Prediction Modes (IntraPredAvailFlags)

Current MB is labelled as X. For non-MBAFF mode, 4 neighbors, A, B, C, D, are depicted in the following picture and are defined as the following.

- MB D: top left neighbor of current MB X
- MB C: top right neighbor of current MB X
- MB B: top neighbor of current MB X
- MB A: left neighbor of the current MB X

mbAddrD D (top-left)	mbAddrB B (top)	mbAddrC C (top-right)
mbAddrA A (left)	X CurrMbAddr X	N/A
N/A	N/A	N/A

For MBAFF mode, the current MB is labelled as X0 or X1, 4 neighbor pairs, A0/A1, B0/B1, C0/C1, D0/D1, are depicted in the following picture and are defined as the following.

- MB D0: first MB of top left neighbor MB pair of current MB pair X0/X1
- MB D1: second MB of top left neighbor MB pair of current MB pair X0/X1
- MB C0: first MB of top right neighbor MB pair of current MB pair X0/X1
- MB C1: second MB of top right neighbor MB pair of current MB pair X0/X1
- MB B0: first MB of top neighbor MB pair of current MB pair X0/X1
- MB B1: second MB of top neighbor MB pair of current MB pair X0/X1
- MB A0: first MB of left neighbor MB pair of the current MB pair X0/X1
- MB A1: second MB of left neighbor MB pair of the current MB pair X0/X1



mbAddrD D0	mbAddrB B0	mbAddrC C0
mbAddrD+1 D1	mbAddrB+1 B1	mbAddrC+1 C1
mbAddrA A0	CurrMbAddrX X0 or	N/A
mbAddrA+1 A1	CurrMbAddrX X1	N/A

For a given macroblock X (or X0/X1), the 6 neighbor availability signals, namely, A, B, C, D, E, F, are defined as the following.

- IntraPredAvailFlagF – F: (Single neighbor pixel at the left 8th row (-1,7))
- IntraPredAvailFlagA – A (Left neighbor top half pixel group)
- IntraPredAvailFlagE – E (Left neighbor bottom half pixel group)
- IntraPredAvailFlagB – B (Top neighbor pixel group)
- IntraPredAvailFlagC – C (Top right neighbor pixel group)
- IntraPredAvailFlagD – D (Top left corner neighbor pixel)

The following table depicts the generation of IntraPredAvailFlags[5:0] signals in a condensed form. It should note that for most cases only one input neighbor signal is assigned for each condition. The exception is in the four places for deriving left neighbor A and E where the neighbor is only available if left neighbors (A0 and A1) are both available (A0&A1). Also note that F takes output value very similar to that for A except the two "AND" conditions, where F is assigned to A1 instead of (A0&A1).



Definition of intra-prediction neighbor availability calculation in MBAFF mode

Output →		D		B		C		A		E		F	
Current X \ Neighbor Y		Y-Frame	Y-Field	Y-Frame	Y-Field	Y-Frame	Y-Field	Y-Frame	Y-Field	Y-Frame	Y-Field	Y-Frame	Y-Field
X₀ (Top)	X-Frame	D₁	D₁	B₁	B₁	C₁	C₁	A₀	A₀ & A₁	A₀	A₀ & A₁	A₀	A₁
	X-Field	D₁	D₀	B₁	B₀	C₁	C₀	A₀	A₀	A₁	A₀	A₀	A₀
X₁ (Bottom)	X-Frame	A₀	A₁	X₀	N/A	0	0	A₁	A₀ & A₁	A₁	A₀ & A₁	A₁	A₁
	X-Field	D₁	D₁	B₁	B₁	C₁	C₁	A₀	A₁	A₁	A₁	A₀	A₁

In *MB Neighbor Availability in Intra-Prediction Modes (IntraPredAvailFlags)*, X-Frame or X-Field indicates the frame/field mode of the current MB; and Y-Frame or Y-Field indicates the corresponding neighbor MB for the given neighbor location, being upper left (D) or left (A) for example. Therefore, "Y-" takes the selected neighbor MB name as in the output cell in the same column. For example, for output D, if X1 is a frame MB, Y = A, if X1 is a field MB, Y = D.

For non-MBAFF mode, as A0=A1, B0=B1, C0=C1 and D0=D1, the neighbor assignment is degenerated into the following simple table. Here, E is assigned to the same as A and F is forced to 0.

Definition of intra-prediction neighbor availability calculation in non-MBAFF mode

Output →	D	B	C	A	E	F
X	D0	B0	C0	A0	A0	0

To further explain the neighbor assignment rules in *MB Neighbor Availability in Intra-Prediction Modes (IntraPredAvailFlags)*, the following table provides description for each condition. Please note that this table is **informative** as it provides redundant information as in *MB Neighbor Availability in Intra-Prediction Modes (IntraPredAvailFlags)*.



Detailed explanation of intra-prediction neighbor availability calculation in MBAFF mode

Current MB	Current MB Field	Neighbor MB Field	Neighbor MB Select (Y=?)	Neighbor Avail Result (OUTPUT)	Description
				D	
X0	X-Frame	Y-Frame	D	D1	Top Frame MB uses [-1,-1] = D_31, thus D1 only, regardless D frame or field pair
(Top)	X-Frame	Y-Field	D	D1	
	X-Field	Y-Frame	D	D1	Top Field MB uses [-1,-2] = D_30, thus if D is frame pair, takes D1 (D1_14 pixel), and if D is field pair, takes D0 (D0_15 pixel)
	X-Field	Y-Field	D	D0	
X1	X-Frame	Y-Frame	A	A0	Bottom Frame MB uses [-1,15] = A_15, thus A0 (A0_15 pixel) if A is a frame pair, or A1 (A1_7 pixel), if A is a field pair
(Bottom)	X-Frame	Y-Field	A	A1	
	X-Field	Y-Frame	D	D1	Bottom Field MB uses [-1,-1] = D_31, thus D1 only, regardless D frame or field pair
	X-Field	Y-Field	D	D1	
				B	
X0	X-Frame	Y-Frame	B	B1	Top Frame MB uses [0...15,-1] = B_31, thus B1 only, regardless B frame or field pair
(Top)	X-Frame	Y-Field	B	B1	
	X-Field	Y-Frame	B	B1	Top Field MB uses [0...15,-2] = B_30, thus if B is frame pair, takes B1 (B1_14 row), and if B is field pair, takes B0 (B0_15 row)
	X-Field	Y-Field	B	B0	
X1	X-Frame	Y-Frame	X	X0	Bottom Frame MB uses [0...15,15], thus X0 (X0_15 row)
(Bottom)	X-Frame	Y-Field	X	n/a	<i>Note: X0 and X1 must have the same field type, this row is n/a.</i>
	X-Field	Y-Frame	B	B1	Bottom Field MB uses [0...15,-1] = B_31, thus B1 only, regardless B frame or field pair
	X-Field	Y-Field	B	B1	
				C	
X0	X-Frame	Y-Frame	C	C1	Top Frame MB uses [16...23,-1] =



Current MB	Current MB Field	Neighbor MB Field	Neighbor MB Select (Y=?)	Neighbor Avail Result (OUTPUT)	Description
				D	
(Top)	X-Frame	Y-Field	C	C1	C_31, thus C1 only, regardless C frame or field pair
	X-Field	Y-Frame	C	C1	Top Field MB uses [16...23,-2] = C_30, thus if C is frame pair, takes C1 (C1_14 row), and if C is field pair, takes C0 (C0_15 row)
	X-Field	Y-Field	C	C0	
X1	X-Frame	Y-Frame	n/a	0	Bottom Frame MB doesn't have left-top neighbor by definition, thus forced to 0
(Bottom)	X-Frame	Y-Field	n/a	0	
	X-Field	Y-Frame	C	C1	Bottom Field MB uses [16...23,-1] = C_31, thus C1 only, regardless C frame or field pair
	X-Field	Y-Field	C	C1	
				A	
X0	X-Frame	Y-Frame	A	A0	First Half of Top Frame MB uses [-1,0...7], thus A0 if A is a frame pair; but is only avail if both A0 and A1 are avail if A is a field pair due to the mix
(Top)	X-Frame	Y-Field	A	A0&A1	
	X-Field	Y-Frame	A	A0	First Half of Top Field MB uses [-1,0..2..4..14], thus take A0 (if A is frame pair, takes A0 even lines, and if A is field pair, takes A0 first half)
	X-Field	Y-Field	A	A0	
X1	X-Frame	Y-Frame	A	A1	First Half of Bottom Frame MB uses [-1,16...23], thus A1 if A is a frame pair; but is only avail if both A0 and A1 are avail if A is a field pair due to the mix
(Bottom)	X-Frame	Y-Field	A	A0&A1	
	X-Field	Y-Frame	A	A0	First Half of Bottom Field MB uses [-1,1..3..15], thus take A0 (if A is frame pair, takes A0 odd lines, and if A is field pair, takes A1 first half)
	X-Field	Y-Field	A	A1	
				E	
X0	X-Frame	Y-Frame	A	A0	Second Half of Top Frame MB uses [-1,8...15], thus A0 if A is a frame pair; but is only avail if both A0 and A1 are avail if A is a field pair due to the mix
(Top)	X-Frame	Y-Field	A	A0&A1	
	X-Field	Y-Frame	A	A1	Second Half of Top Field MB uses [-1,16..18..30], thus take A1 (if A is frame pair, takes A1 even lines, and if A is field pair, takes A0 second half)
	X-Field	Y-Field	A	A0	
X1	X-Frame	Y-Frame	A	A1	Second Half of Bottom Frame MB



Current MB	Current MB Field	Neighbor MB Field	Neighbor MB Select (Y=?)	Neighbor Avail Result (OUTPUT)	Description
				D	
(Bottom)	X-Frame	Y-Field	A	A0&A1	uses [-1,24...31], thus A1 if A is a frame pair; but is only avail if both A0 and A1 are avail if A is a field pair due to the mix
	X-Field	Y-Frame	A	A1	Second Half of Bottom Field MB uses [-1,17..19..31], thus takes A1 (if A is frame pair, takes A1 odd lines, and if A is field pair, takes A1 second half)
	X-Field	Y-Field	A	A1	
				F	
X0	X-Frame	Y-Frame	A	A0	Top Frame MB uses [-1,7] = A_7 (odd location), thus A0 if A is frame pair and A1 if field pair
(Top)	X-Frame	Y-Field	A	A1	
	X-Field	Y-Frame	A	A0	Top Field MB uses [-1,14] = A_14 (even location), thus A0 regardless A frame or field pair
	X-Field	Y-Field	A	A0	
X1	X-Frame	Y-Frame	A	A1	Bottom Frame MB uses [-1,23] = A_23 (odd location), thus A1 regardless A frame or field pair
(Bottom)	X-Frame	Y-Field	A	A1	
	X-Field	Y-Frame	A	A0	Bottom Field MB uses [-1,15] = A_15 (odd location), thus A0 if A is frame pair and A1 if A is field pair
	X-Field	Y-Field	A	A1	

Macroblock Type for Intra Cases

MbType follows two different tables according to whether the macroblock is an inter or intra macroblock according to IntraMbFlag.

For an intra macroblock, MbType, as defined in *Macroblock Type for Intra Cases*, carries redundant information as IntraMbMode. The notation I_16x16_x_y_z used in the table, 'x' is Intra16x16LumaPredMode, 'y' is ChromaCbInd, and 'z' is LumaCbInd, as defined in *Macroblock Type for Intra Cases*.



MbType definition for Intra Macroblock

Macroblock Type	MbType
I_4x4	0
I_8x8	0
I_16x16_0_0_0	1
I_16x16_1_0_0	2
I_16x16_2_0_0	3
I_16x16_3_0_0	4
I_16x16_0_1_0	5
I_16x16_1_1_0	6
I_16x16_2_1_0	7
I_16x16_3_1_0	8
I_16x16_0_2_0	9
I_16x16_1_2_0	Ah
I_16x16_2_2_0	Bh
I_16x16_3_2_0	Ch
I_16x16_0_0_1	Dh
I_16x16_1_0_1	Eh
I_16x16_2_0_1	Fh
I_16x16_3_0_1	10h
I_16x16_0_1_1	11h
I_16x16_1_1_1	12h
I_16x16_2_1_1	13h
I_16x16_3_1_1	14h



Macroblock Type	MbType
I_16x16_0_2_1	15h
I_16x16_1_2_1	16h
I_16x16_2_2_1	17h
I_16x16_3_2_1	18h
I_PCM	19h (used by HW)

Note: MbType here is identical as specified in DXVA 2.0.

For Intra_16x16 modes, the 5 bits of value (MbType – 1) have the following meanings.



Sub field definition used by MbType for a macroblock with Intra16x16 prediction

Bits	Description
4	<p>LumaCbInd – Luma Coded Block Pattern Indicator</p> <p>0 means none of the luma blocks are coded. 1 means that at least one luma block is coded.</p> <p>0 = SUBMODE_I16_L_0 1 = SUBMODE_I16_L_NZ</p> <p>In VME output, this field is forced to be 1 before adding 1 in Intra_16x16 mode.</p>
3:2	<p>ChromaCbInd – Chroma Coded Block Pattern Indicator</p> <p>00 means none of chroma blocks are coded. 01 means that only the chroma DC block is coded, but all AC blocks are not coded. 10 means that at least one AC chroma block is coded.</p> <p>00 = SUBMODE_I16_C_0 01 = SUBMODE_I16_C_DC 10 = SUBMODE_I16_C_NZ 11 = Reserved</p> <p>In VME output, this field is forced to be 10 before adding 1 in Intra_16x16 mode.</p> <p><i>Programming Note: Adding 1 to MbType by VME hardware may have carry in to this field. But as '11' is reserved, the carry-in doesn't propagate into bit 4 or higher. This allows software to update MbType, if desired, using the redundant LumaIntraPredModes information.</i></p>
1:0	<p>Intra16x16PredMode – Intra16x16 Prediction Mode</p> <p>These two bits carries redundant (identical) information as that in LumaIntraPredModes[0][0].</p> <p>0 = SUBMODE_I16_VER 1 = SUBMODE_I16_HOR 2 = SUBMODE_I16_DC 3 = SUBMODE_I16_PLANE</p>



IntraMbMode definition

IntraMbMode [1:0]	Description	Supported by VME?	Used by PAK?
0	INTRA_16x16 (redundant with MbType)	Yes	Ignored
1	INTRA_8x8	Yes	Yes
2	INTRA_4x4	Yes	Yes
3	IPCM (redundant with MbType)	No	Ignored

As an alternative representation, MbType is logically the same as the following, except the I_PCM and I_NxN (i.e. I_4x4 and I_8x8) cases:

- 24 types of 16x16 intra modes: **A+B+C+D**: (1h – 18h)

MBTYPE_INTRA_16x16 1h A

- 4 Intra16x16 modes:

SUBMODE_I16_VER 0 B

SUBMODE_I16_HOR 1 B

SUBMODE_I16_DC 2 B

SUBMODE_I16_PLN 3 B

- 3 Chroma Cbp indices:

SUBMODE_I16_C_0 0 C

SUBMODE_I16_C_DC 4 C

SUBMODE_I16_C_NZ 8 C

- 2 Luma Cbp indices:

SUBMODE_I16_L_0 0 D

SUBMODE_I16_L_NZ Ch D



Macroblock Type for Inter Cases

Sub-Macroblock Prediction Mode, `SubMbPredMode`, indicates the prediction mode for the sub-partitions. Prediction mode specifies prediction direction being forward (from L0), backward (from L1) or bi-directional (from both L0 and L1). Its meaning depends on `InterMbMode`. *Macroblock Type for Inter Cases* provides the definition of the field.

- If `InterMbMode` is `INTER16x16`, only `SubMbPredMode[0]` is valid, it describes the prediction mode of the 16x16 macroblock. The other entries are set to zero by hardware.
 - For AVC, `SubMbPredMode[0]` contains redundant information as encoded in `MbType` parameter.
 - *Note: `SubMbPredMode[1]-[3]` are intentionally set to zero to allow a simple LUT to derive `MbType` as described later.*
- If `InterMbMode` is `INTER16x8`, and `INTER8x16`, only the first two entries `SubMbPredMode[0]` and `SubMbPredMode[1]` are valid, describing the sub-macroblock prediction mode.
 - For AVC, `SubMbPredMode[0]/[1]` contains redundant information as encoded in `MbType` parameter.
 - *Note: `SubMbPredMode[2]-[3]` are intentionally set to zero to allow a simple LUT to derive `MbType` as described later.*
- If `InterMbMode` is `INTER8x8`, each entry of `SubMbPredMode` describes the prediction mode of the sub-partition of an 8x8 sub-macroblock.
 - For AVC, `SubMbPredMode` can be derived from `sub_mb_type` field for `BP_8x8` macroblocks as defined in AVC spec.
 - *Note on Direct Sub-macroblock Prediction Mode: Direct prediction is not conveyed through `SubMbPredMode`, instead, it is carried through `Direct8x8Pattern`.*



InterMbMode definition

MbSkipFlag	InterMbMode	Description
0	0	INTER16x16
0	1	INTER16x8
0	2	INTER8x16
0	3	INTER8x8
1	0	PSKIP/BSKIP16x16*
1	3	BSKIP
1	1, 2	Reserved
Used by PAK	Ignored by PAK	

* BSKIP16x16 is an optional non-standard but equivalent optimization.

Definition of SubMbPredMode based on InterMbMode

SubMbPredMode	INTER16x16	INTER16x8	INTER8x16	INTER8x8
Bit	MbType = [1...3]	MbType = [16h]	MbType = [4...15h]	MbType = [16h]
7:6	MBZ	MBZ	MBZ	Block8x8 3
5:4	MBZ	MBZ	MBZ	Block8x8 2
3:2	MBZ	Block16x8 1	Block8x16 1	Block8x8 1
1:0	Block16x16	Block16x8 0	Block8x16 0	Block8x8 0
	Ignored by PAK	Ignored by PAK	Ignored by PAK	Used by PAK



Definition of SubMbPredMode[i]

SubMbPredMode	Description	InterMbMode	VME Output	MvCountPred	Notes
0	Pred_L0	All	Yes	1	P or B Slice
1	Pred_L1	All	Yes	1	B Slice Only
2	BiPred	All	Yes	2	B Slice Only
3	Reserved	Reserved	Reserved	Reserved	Reserved

Sub-Macroblock Shape, SubMbShape[i], for $i = 0...3$, describes the shape of the sub partitions of the 8x8 sub-macroblock of a BP_8x8 macroblock. This field is only valid if InterMBMode is INTER8x8. They are defined in *Macroblock Type for Inter Cases*. The parameters can be derived from *sub_mb_type* field as defined in AVC spec.

Note: These fields must be correctly set even for **Direct** or **Skip** 8x8 cases, the individual B_Direct_8x8 block is flagged by the **Direct8x8Pattern** variable.

Definition of SubMbShape for an 8x8 region of a BP_8x8 macroblock (including BSKIP, BDIRECT)

SubMbShape	Description			
	NumSubMbPart	SubMbPartWidth	SubMbPartHeight	MvCountShape
0	1	8	8	1
1	2	8	4	2
2	2	4	8	2
3	4	4	4	4

For an inter macroblock, MbType, carries redundant information as InterMbMode and SubMbPredMode. *Macroblock Type for Inter Cases* provides the typical inter macroblock types and *Macroblock Type for Inter Cases* provides that with skip and direct modes. The definition of MbType for both P slice and B slice is the same and is equivalent to that for mb_type of a B slice in the AVC spec. As direct mode is indicated using a separate field Direct8x8Pattern, 0 is reserved for MbType.

Here, MVCount is the number of motion vectors actually encoded in the bitstream. It is informative. For a BP_8x8 or equivalent Skip/Direct macroblock, MVCount is the sum of the following term for the four 8x8 sub macroblock (with $i = 0...3$):

$$\text{MvCountShape}[i] * \text{MvCountPred}[i] * \text{MvCountDirect}[i]$$

where MvCountShape[i] is block count for sub macroblock [i], MvCountPred[i] is the motion vector count for each block of sub macroblock[i], and MvCountDirect[i] is the multiplier for direct mode for B Slice, indicating whether motion vectors are coded or not. It must be set to 1 for P slice. For B Slice,



MvCountDirect[i] = !Direct8x8Pattern[i], which is 0 for a sub macroblock coded as direct mode and 1 otherwise.

In the tables, "DC" stands for "Don't Care" as PAK hardware ignores these fields.

MbType definition for Inter Macroblock (and MbSkipflag = 0)

Macroblock Type	MbType	MbSkipFlag	Direct8x8Pattern	SubMbShape	SubMbPredMode	MVCount
<i>Reserved</i>	0	-	-	-	-	-
<i>BP_L0_16x16</i>	1	0	0	DC	DC	1
<i>B_L1_16x16</i>	2	0	0	DC	DC	1
<i>B_Bi_16x16</i>	3	0	0	DC	DC	2
<i>BP_L0_L0_16x8</i>	4	0	0	DC	DC	2
<i>BP_L0_L0_8x16</i>	5	0	0	DC	DC	2
<i>B_L1_L1_16x8</i>	6	0	0	DC	DC	2
<i>B_L1_L1_8x16</i>	7	0	0	DC	DC	2
<i>B_L0_L1_16x8</i>	8	0	0	DC	DC	2
<i>B_L0_L1_8x16</i>	9	0	0	DC	DC	2
<i>B_L1_L0_16x8</i>	0Ah	0	0	DC	DC	2
<i>B_L1_L0_8x16</i>	0Bh	0	0	DC	DC	2
<i>B_L0_Bi_16x8</i>	0Ch	0	0	DC	DC	3
<i>B_L0_Bi_8x16</i>	0Dh	0	0	DC	DC	3
<i>B_L1_Bi_16x8</i>	0Eh	0	0	DC	DC	3
<i>B_L1_Bi_8x16</i>	0Fh	0	0	DC	DC	3
<i>B_Bi_L0_16x8</i>	10h	0	0	DC	DC	3
<i>B_Bi_L0_8x16</i>	11h	0	0	DC	DC	3
<i>B_Bi_L1_16x8</i>	12h	0	0	DC	DC	3



Macroblock Type	MbType	MbSkipFlag	Direct8x8Pattern	SubMbShape	SubMbPredMode	MVCount
B_Bi_L1_8x16	13h	0	0	DC	DC	3
B_Bi_Bi_16x8	14h	0	0	DC	DC	4
B_Bi_Bi_8x16	15h	0	0	DC	DC	4
BP_8x8	16h	0	!= Fh	vary	vary	Sum
<i>Reserved</i>	17h-1Fh	-	-	-	-	-

Additional MbType definition with Direct/Skip for Inter Macroblock

Macroblock Type	Mb Type	Xfrm 8x8	MbSkip Flag	Direct 8x8 Pattern	SubMb Shape	SubMb PredMode	MvCount	Notes
P_Skip_16x16	1	-	1	DC	DC	DC	0	Skipped macroblock. Motion compensation like P_L0_16x16
B_Skip_16x16_4MVPair	16h	vary	1	Fh	0	vary	0	Skipped macroblock. Motion compensation like B_8x8 with 8x8 subblocks, when direct_8x8_inference_flag is set to 1
B_Skip_16x16_16MVPair	16h	0	1	Fh	FFh	vary	0	Skipped macroblock. Motion compensation like B_8x8 with 4x4 subblocks, when direct_8x8_inference_flag is set to 0
B_Direct_16x16_4MVPair	16h	vary	0	Fh	0	vary	0	MbType coded as B_Direct_16x16. Motion compensation like B_8x8 with 8x8 subblocks, when direct_8x8_inference_flag is set to 1
B_Direct_16x16_16MVPair	16h	0	0	Fh	FFh	vary	0	MbType coded as B_Direct_16x16. Motion compensation like B_8x8 with 4x4 subblocks,



Macroblock Type	Mb Type	Xfrm 8x8	MbSkip Flag	Direct 8x8 Pattern	SubMb Shape	SubMb PredMode	MvCount	Notes
								when <code>direct_8x8_inference_flag</code> is set to 0

People might notice that B_DIRECT_16x16 and B_SKIP are mapped on BP_8x8 for AVC decoding interface in IT mode as the motion compensation operation for both modes are the same as BP_8x8. According to AVC Spec, motion vectors for B_DIRECT_16x16 and B_SKIP are derived from temporally co-located macroblock on an 8x8 sub macroblock basis if `direct_8x8_inference_flag` is set to 1 or on a 4x4 block basis if it is set to 0. For each sub macroblock or block, SubMbPredMode is derived, thus can any of the valid numbers. Motion vectors may also be different. In spatial direct mode, the motion vectors are subject to spatial neighbor macroblocks as well as co-located macroblock. The spatial prediction is based on the neighbor macroblocks, so the same spatial predicted motion vector applies to all sub macroblocks or blocks. However, under certain conditions, temporal predictor may replace (`colZeroFlag`) the spatial predictor for a given sub macroblock or block. Thus the motion vectors may differ.

In *Macroblock Type for Inter Cases*, the macroblock type names for major partitions nicely follow forms *BP_MbPredMode_MbShape* (like BP_LO_16x16) and *B_MbPredMode0_MbPredMode1_MbShape* (like B_LO_Bi_16x8). For minor partitions it is fixed as *BP_MbShape* as BP_8x8.

However, in *Macroblock Type for Inter Cases* the macroblock types for Skip and Direct modes does not follow the same rule. The third field in P_Skip_16x16 or B_Direct_16x16_x indicates that "Skip" or "Direct" applies to the entire 16x16 macroblock, even though MbShape is 8x8 as that in BP_8x8. In order to distinguish the SubMbShape being 8x8 or 4x4 for B_Skip and B_Direct, the fourth field is added. 4MVPair indicates upto 4 MV pairs are presented with SubMbShape equals to 0; and 16MVPair indicates up to 16 MV pairs are presented with SubMbShape equals to FFh. Also note that P_8x8ref0 is not specified in PAK input interface, it is up to hardware to detect and choose its packing format based on number of reference indices and reference index for the given macroblock.

Macroblock Type Conversion Rules

For improved coding efficiency the PAK hardware has the capability to convert macroblock types to use more efficiency coding modes such as DIRECT and SKIP. For an inter macroblock or a sub macroblock coded as DIRECT, no motion vector is needed in the bitstream for the macroblock or sub macroblock. If a macroblock is coded as SKIP, it only consumes one SKIP bit (no motion vector, no coefficients are coded). And information about the macroblock is 'inferred' according to the rules stated in the AVC Spec.

As the input to PAK, the following signals can convey the information regarding DIRECT and SKIP:

- MbSkipFlag
- Direct8x8Pattern
- CodecBlockPattern (CbpY, CbpCb, CbpCr)



Such conversion can be enabled or disabled through the SLICE_STATE fields **DirectConvDisable** and **SkipConvDisable** as well as the in line command field **MbSkipConvDisable**.

A P slice doesn't support direct mode, it only supports P_Skip, which is equivalent to a 16_16_L0 prediction. Other prediction types cannot be converted to P_Skip. The following table describes the macroblock type conversion rules for a P slice. Here CBP = CbpY/CbpCb/CbpCr are the final computed results after quantization by the hardware. Note that hardware honors the input CbpY/CbpCb/CbpCr fields – if the value corresponding to a block is set to zero, the resulting CBP is also zero. The output **mb_skip_flag** and **mb_type** are the symbols coded in the bitstream as defined in the AVC spec. "DC" stands for "Don't care", "T" for "True".

Note that the internal condition of MV==MVP is subject to the precise rules stated in the AVC Spec as quoted below. Note that there are exceptions for P_Skip from the normal motion vector prediction rules.

Derivation process for luma motion vectors for skipped macroblocks in P and SP slices

This process is invoked when mb_type is equal to P_Skip.

Outputs of this process are the motion vector mvL0 and the reference index refldxL0.

The reference index refldxL0 for a skipped macroblock is derived as follows.

refldxL0 = 0. (8-168)

For the derivation of the motion vector mvL0 of a P_Skip macroblock type, the following applies.

– *The process specified in subclause 8.4.1.3.2 is invoked with mbPartIdx set equal to 0, subMbPartIdx set equal to 0, currSubMbType set equal to "na", and listSuffixFlag set equal to 0 as input and the output is assigned to mbAddrA, mbAddrB, mvLOA, mvLOB, refldxLOA, and refldxLOB.*

– *The variable mvL0 is specified as follows.*

– *If any of the following conditions are true, both components of the motion vector mvL0 are set equal to 0.*

– *mbAddrA is not available*

– *mbAddrB is not available*

– *refldxLOA is equal to 0 and both components of mvLOA are equal to 0*

– *refldxLOB is equal to 0 and both components of mvLOB are equal to 0*

– *Otherwise, the derivation process for luma motion vector prediction as specified in subclause 8.4.1.3 is invoked with mbPartIdx = 0, subMbPartIdx = 0, refldxL0, and currSubMbType = "na" as inputs and the output is assigned to mvL0.*

NOTE – The output is directly assigned to mvL0, since the predictor is equal to the actual motion vector.



Macroblock type conversion rule for an inter macroblock in a P slice

Input		Internal			Output		Notes
Macroblock Type	SkipConvDisable SkipConvDisable	CBP	MV == MVP	MbAffSkipAllowed	mb_skip_flag	mb_type	
P_Skip_16x16	DC	DC	DC	1	1	-	Forced to P_Skip; Hardware will force CBP to zero and also ignore SkipConvDisable control. Hardware doesn't check for MV==MVP error condition
P_Skip_16x16	DC	DC	DC	0	0	0	Reverse convert to P_LO_16x16; Hardware will force CBP to zero but reversely convert MbType as P_LO_16x16 once it determines that Skip is not allowed.
BP_16x16_LO	0	0	T	1	1	-	Converted to P_Skip. Even input doesn't provide skip hint, hardware can performance the optimization by detecting CBP and MV==MVP condition.
BP_16x16_LO	0	0	T	0	0	0	Reverse back to P_LO_16x16; Hardware will reverse back to P_LO_16x16 even Skip conditions are met once it determines that Skip is not allowed.



Input		Internal			Output		Notes
Macroblock Type	SkipConvDisable SkipConvDisable	CBP	MV == MVP	MbAffSkipAllowed	mb_skip_flag	mb_type	
BP_16x16_L0	1	0	T	T	0	0	Still coded as P_L0_16x16 = 0.

A B slice supports both direct and skip modes. The following table describes the macroblock type conversion rules for a B slice. Hardware does not verify MV==MVP condition for a Skip/Direct macroblock in a B Slice as no DMV is performed by hardware.



Macroblock type conversion rule for an inter macroblock in a B slice

Input				Internal		Output		Notes
Macroblock Type	SkipConvDisable SkipConvDisable	DirectConvDisable	CBP	MV == MV P	MbAffS kip Allowed	mb_skip_flag	mb_type	
B_Skip_8x8 B_Skip_4x4	DC	DC	DC	n/a	1	1	-	Forced to B_Skip; Hardware will force CBP to zero and also ignore SkipConvDisable control.
B_Skip_8x8 B_Skip_4x4	DC	DC	DC	n/a	0	0	0	REVERSE convert to B_Direct_16x16; Hardware will force CBP to zero and also reverse convert to B_Direct_16x16 when it discovers Skip is not allowed.
B_Direct_16x16_4MVPair/16MVPair	0	0	0	n/a	1	1	-	Converted to B_Skip. Hardware first converts to B_Direct_16x16 and then further to B_Skip if CBP = 0.
B_Direct_16x16_4MVPair/16MVPair	0	0	0	n/a	0	0	0	Converted to B_Direct_16x16. Hardware first converts to B_Direct_16x16 and stop there as it discovers



Input			Internal			Output		Notes
Macroblock Type	SkipConvDisable SkipConvDisable	DirectConvDisable	CBP	MV == MV P	MbAffSkip Allowed	mb_skip_flag	mb_type	
								Skip is not allowed even CBP=0.
B_Direct_16x16_4MVPair/16MVPair	1	0	0	n/a	DC	0	0	Converted to B_Direct_16x16. Hardware converts to B_Direct_16x16 and stops there even though CBP = 0 as input disallows Skip conversion.
B_Direct_16x16_4MVPair/16MVPair	DC	0	NZ	n/a	DC	0	0	Converted to B_Direct_16x16. Hardware converts to B_Direct_16x16 and stops there because CBP != 0.
B_Direct_16x16_4MVPair/16MVPair	DC	1	DC	n/a	DC	0	16h	

The internal signal **MbAffSkipAllowed** is added to deal with a restriction on the frame/field flag (**MbFieldFlag**) which is unique to MBAFF. **MbAffSkipAllowed** is always set to 1 in non-MBAFF modes. In MBAFF mode, a macroblock pair may be both skipped only if its **MbFieldFlag** is the same as its available neighbor macroblock pair A or B if A or B is available (in that order), or is not 0 if A/B are both not available. Otherwise, one of the macroblocks in the pair must be coded.

To reduce the burden on software, PAK hardware handles the above restriction correctly. For the first MB in a pair, **MbAffSkipAllowed** is always set to 1. Therefore, hardware allows converting the first MB to Skip if skip conversion is enabled. For the second MB in a pair, hardware sets **MbAffSkipAllowed** to 0 if the following is true:



- The current MB Pair has different **MbFieldFlag** than its available neighbor A or B if A or B is available, or is not 0 if A/B are both not available
- And the first MB is coded as a SKIP (could be forced or converted)

Otherwise, it sets **MbAffSkipAllowed** to 1. As **MbAffSkipAllowed** is to 0 for the above condition, hardware will disallow Skip mode for the second MB. If the input signal forces it to Skip, hardware performs reverse-conversion to code it as P_L0_16x16 or B_Direct_16x16 with CBP = 0 for a macroblock in a P or B Slice. This means that hardware is able to correct the programming mistake by software. If the macroblock is not forced to skip, hardware simply disallows Skip conversion.

Software still has an option to disallow Skip Conversion on a per-MB basis using the **MbSkipConvDisable** control field in the inline command.

Indirect Data Description

For each macroblock, an ENC-PAK data set consists of two types of data blocks: indirect **MV data block** and **inline MB information**.

The indirect MV data block may be in two modes: **unpackedmode** and **packed-size mode**.

Unpacked Motion Vector Data Block

In the **unpacked** mode, motion vectors are expanded (or duplicated) to either bidirectional 8x8 8MV major partition format, or bidirectional 4x4 32MV format. Thus either 32 bytes or 128 bytes is assigned to each MB.

Motion Vector block contains motion vectors in an intermediate format that is partially expanded according to the sub- macroblock size. During the expansion, a place that does not contain a motion vector is filled by replicating the relevant motion vector according to the following motion vector replication rules. If the relevant motion vector doesn't exist (for the given L0 or L1), it is zero filled.

Motion Vector Replication Rules:

- Rule #1
 - #1.1: For L0 MV, for any sub-macroblock or sub-partition where there is at least one motion vector
 - If L0 inter prediction exists, the corresponding L0 MV is used
 - Else it must be zero
 - #1.2: For L1 MV, for any sub-macroblock or sub-partition where there is at least one motion vector
 - If L1 inter prediction exists, the corresponding L1 MV is used
 - Else it must be zero
- For a macroblock with a 16x16, 16x8 or 8x16 sub-macroblock, MvSize = 8. The eight MV fields follow Rule #1.



- The 16x16 is broken down into 4 8x8 sub-macroblocks. The 16x16 MVs (after rule #1) are replicated into all 8x8 blocks.
- For an 8x16 partition, each 8x16 is broken down into 2 8x8 stacking vertically. The 8x16 MVs (after rule #1) are replicated into both 8x8 blocks.
- For a 16x8 partition, each 16x8 is broken down into 2 8x8 stacking horizontally. The 16x8 MVs (after rule #1) are replicated into both 8x8 blocks.
- For macroblock with sub-macroblock of 8x8 without minor partition (SubMbShape[0...3] = 0), MvSize = 8, (e.g. mb_type equal to P_8x8, P_8x8ref0, or B_8x8)
 - There is no motion vector replication
- For macroblock with sub-macroblock of 8x8 with at least one minor partition (if any SubMbShape[i] != 0), MvSize = 32, (e.g. mb_type equal to P_8x8, P_8x8ref0, or B_8x8)
 - For an 8x8 sub-partition, the 8x8 MVs (after rule #1) is replicated into all the four 4x4 blocks.
 - For an 4x8 sub-partition within an 8x8 partition, each 4x8 is broken down into 2 4x4 stacking vertically. The 4x8 MVs (after rule #1) are replicated into both 4x4 blocks.
 - For an 8x4 sub-partition within an 8x8 partition, each 8x4 is broken down into 2 4x4 stacking horizontally. The 8x4 MVs (after rule #1) are replicated into both 4x4 blocks.
 - For a 4x4 sub-partition within an 8x8 partition, each 4x4 has its own MVs (after rule #1).

Motion Vector block and MvSize

DWord	Bit	MvSize	
		8	32
W1.0	31:16	MV_Y0_L0.y	MV_Y0_0_L0.y
	15:0	MV_Y0_L0.x	MV_Y0_0_L0.x
W1.1	31:16	MV_Y0_L1.y	MV_Y0_0_L1.y
	15:0	MV_Y0_L1.x	MV_Y0_0_L1.x
W1.2	31:0	MV_Y1_L0	MV_Y0_1_L0
W1.3	31:0	MV_Y1_L1	MV_Y0_1_L1
W1.4	31:0	MV_Y2_L0	MV_Y0_2_L1
W1.5	31:0	MV_Y2_L1	MV_Y0_2_L0
W1.6	31:0	MV_Y3_L0	MV_Y0_3_L0



DWord	Bit	MvSize	
		8	32
W1.7	31:0	MV_Y3_L1	MV_Y0_3_L1
W2.0	31:0	n/a	MV_Y1_0_L1
W2.1	31:0	n/a	MV_Y1_0_L0
W2.2	31:0	n/a	MV_Y1_1_L1
W2.3	31:0	n/a	MV_Y1_1_L0
W2.4	31:0	n/a	MV_Y1_2_L1
W2.5	31:0	n/a	MV_Y1_2_L0
W2.6	31:0	n/a	MV_Y1_3_L0
W2.7	31:0	n/a	MV_Y1_3_L1
W3.0	31:0	n/a	MV_Y2_0_L1
W3.1	31:0	n/a	MV_Y2_0_L0
W3.2	31:0	n/a	MV_Y2_1_L1
W3.3	31:0	n/a	MV_Y2_1_L0
W3.4	31:0	n/a	MV_Y2_2_L1
W3.5	31:0	n/a	MV_Y2_2_L0
W3.6	31:0	n/a	MV_Y2_3_L0
W3.7	31:0	n/a	MV_Y2_3_L1
W4.0	31:0	n/a	MV_Y3_0_L1
W4.1	31:0	n/a	MV_Y3_0_L0
W4.2	31:0	n/a	MV_Y3_1_L1



DWord	Bit	MvSize	
		8	32
W4.3	31:0	n/a	MV_Y3_1_L0
W4.4	31:0	n/a	MV_Y3_2_L1
W4.5	31:0	n/a	MV_Y3_2_L0
W4.6	31:0	n/a	MV_Y3_3_L0
W4.7	31:0	n/a	MV_Y3_3_L1

The motion vector(s) for a given sub-macroblock or a sub-partition are uniquely placed in the output message as shown by the non-duplicate fields in *Unpacked Motion Vector Data Block* and *Unpacked Motion Vector Data Block*.

MV_Yx_L0 and MV_Yx_L1 may be present individually or both. If one is not present, the corresponding field must be zero. Subsequently, the duplicated fields will be zero as well.

Motion Vector duplication by sub-macroblocks for a 16x16 macroblock, whereas the 8x8 column is for 4x(8x8) partition without minor shape

DWord	Bit	16x16	16x8	8x16	8x8
W1.0	31:16	MV_Y0_L1 (A)	MV_Y0_L1 (A)	MV_Y0_L1	MV_Y0_L1
	15:0	MV_Y0_L0 (A)	MV_Y0_L0 (A)	MV_Y0_L0	MV_Y0_L0
W1.1	31:16	Duplicate (A)	Duplicate (A)	MV_Y1_L1	MV_Y1_L1
	15:0	Duplicate (A)	Duplicate (A)	MV_Y1_L0	MV_Y1_L0
W1.2	31:16	Duplicate (A)	MV_Y2_L1 (B)	Duplicate (A)	MV_Y2_L1
	15:0	Duplicate (A)	MV_Y2_L0 (B)	Duplicate (A)	MV_Y2_L0
W1.3	31:16	Duplicate (A)	Duplicate (B)	Duplicate (B)	MV_Y3_L1
	15:0	Duplicate (A)	Duplicate (B)	Duplicate (B)	MV_Y3_L0



Motion Vector duplication by sub-partitions for the first 8x8 sub-macroblock Y0 if any Y0-Y3 contains minor shape (Y1_ to Y3_ have the same format in W2 to W4)

DWord	Bit	8x8	8x4	4x8	4x4
W1.0	31:16	MV_Y0_L1	MV_Y0_0_L1 (A)	MV_Y0_0_L1 (A)	MV_Y0_0_L1
	15:0	MV_Y0_L0	MV_Y0_0_L0 (A)	MV_Y0_0_L0 (A)	MV_Y0_0_L0
W1.1	31:16	Duplicate (A)	Duplicate (A)	MV_Y0_1_L1 (B)	MV_Y0_1_L1
	15:0	Duplicate (A)	Duplicate (A)	MV_Y0_1_L0 (B)	MV_Y0_1_L0
W1.2	31:16	Duplicate (A)	MV_Y0_2_L1 (B)	Duplicate (A)	MV_Y0_2_L1
	15:0	Duplicate (A)	MV_Y0_2_L0 (B)	Duplicate (A)	MV_Y0_2_L0
W1.3	31:16	Duplicate (A)	Duplicate (B)	Duplicate (B)	MV_Y0_3_L0
	15:0	Duplicate (A)	Duplicate (B)	Duplicate (B)	MV_Y0_3_L1



Packed-Size Motion Vector Data Block

In the packed case, no redundant motion vectors are sent. So the number of motion vectors sent, as specified by **MvQuantity** is the same as the motion vectors that will be packed (**MvPacked**).

The following tables are for information only. Fields like MvQuantity and MvPacked are not required interface fields.

MbSkipFlag	MbType	Description	Mv Quantity	MvSize	(Minimal MvSize)
1	1	P_Skip_16x16	0	8	1
0	1	BP_L0_16x16	1	8	1
0	2	B_L1_16x16	1	8	1
0	3	B_Bi_16x16	2	8	2
0	4	BP_L0_L0_16x8	2	8	4
0	5	BP_L0_L0_8x16	2	8	4
0	6	B_L1_L1_16x8	2	8	8
0	7	B_L1_L1_8x16	2	8	8
0	8	B_L0_L1_16x8	2	8	8
0	9	B_L0_L1_8x16	2	8	8
0	0Ah	B_L1_L0_16x8	2	8	8
0	0Bh	B_L1_L0_8x16	2	8	8
0	0Ch	B_L0_Bi_16x8	3	8	8
0	0Dh	B_L0_Bi_8x16	3	8	8
0	0Eh	B_L1_Bi_16x8	3	8	8
0	0Fh	B_L1_Bi_8x16	3	8	8
0	10h	B_Bi_L0_16x8	3	8	8
0	11h	B_Bi_L0_8x16	3	8	8
0	12h	B_Bi_L1_16x8	3	8	8
0	13h	B_Bi_L1_8x16	3	8	8
0	14h	B_Bi_Bi_16x8	4	8	8
0	15h	B_Bi_Bi_8x16	4	8	8
0	16h	BP_8x8	≥4	8 or 32	8 or 32



When MbType = 22, BP_8x8, take the sum of four individual 8x8 subblocks

Direct8x8Pattern	SubMb Shape	SubMb PredMode	Description	Mv Quantity	Mv Size	(Min MvSize)
OR	OR	OR		ADD	ADD	ADD
1	0	0	P_Skip_8x8 B_Direct_L0_8x8 (B-Skip_L0_8x8)	0	2	1
1	0	1	B_Direct_L1_8x8 (B-Skip_L1_8x8)	0	2	1
1	0	2	B_Direct_Bi_8x8 (B-Skip_Bi_8x8)	0	2	2
1	3	0	P_Skip_4x4 B_Direct_L0_4x4 (B-Skip_L0_4x4)	0	8	4
1	3	1	B_Direct_L1_4x4 (B-Skip_L1_4x4)	0	8	4
1	3	2	B_Direct_Bi_4x4 (B-Skip_Bi_4x4)	0	8	8
0	0	0	BP_L0_8x8	1	2	1
0	0	1	B_L1_8x8	1	2	1
0	0	2	B_BI_8x8	2	2	2
0	1	0	BP_L0_8x4	2	8	4
0	1	1	B_L1_8x4	2	8	4
0	1	2	B_BI_8x4	4	8	8
0	2	0	BP_L0_4x8	2	8	4
0	2	1	B_L1_4x8	2	8	4
0	2	2	B_BI_4x8	4	8	8
0	3	0	BP_L0_4x4	4	8	4
0	3	1	B_L1_4x4	4	8	4
0	3	2	B_BI_4x4	8	8	8

Macroblock Level Rate Control

The QRC (Quantization Rate Control) unit receives data from BSP (Bit Serial Packer) and VIN (Video In) and generates adjustments to QP values across macroblocks.

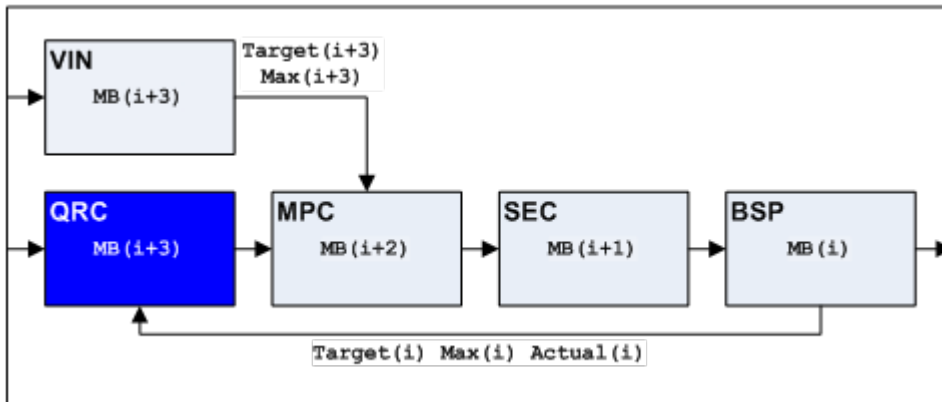

QRC can be logically partitioned into two units as shown below.

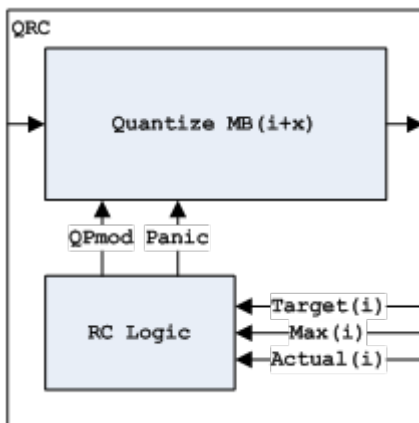

Macroblock level rate control is handled by the RC logic and the quantization logic.

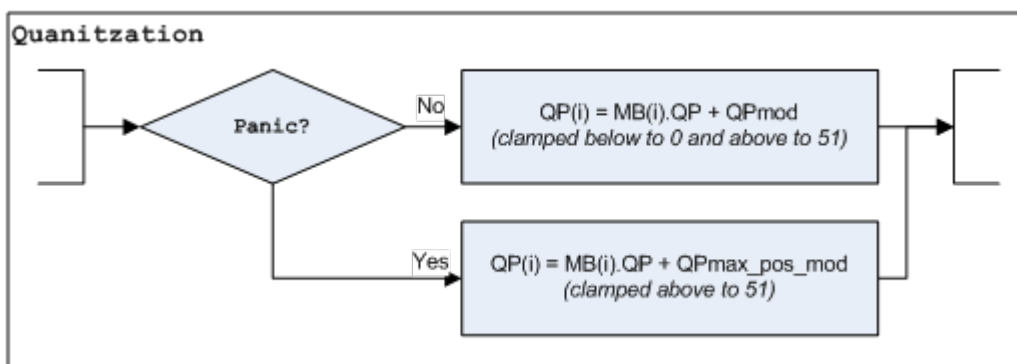

The signals QPmod and panic are generated by the RC logic based on data feedback from BSP. A flowchart of the RC logic is given below.

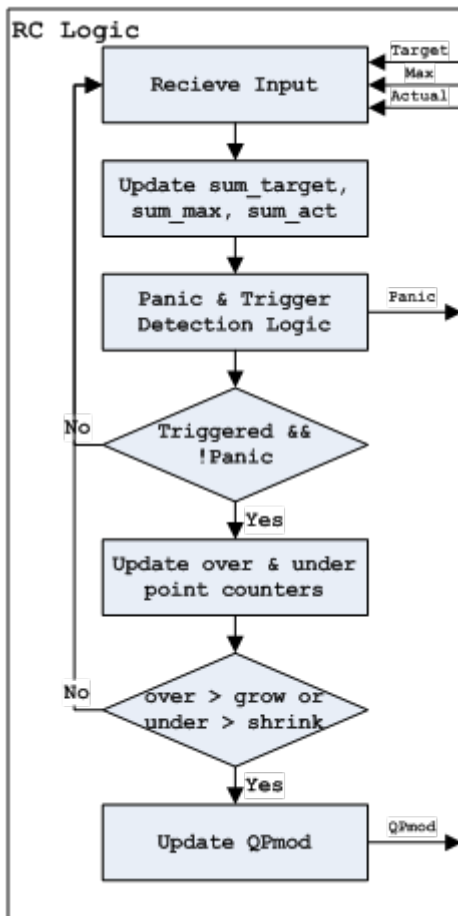

Theory of Operation Overview

BSP will generate a byte estimate for each macroblock packed. Additionally, the user will specify a target and max size per macroblock. The running sum of these signals (actual, target, max) creates "curves" which are used to identify when QP adjustments are necessary (see figure below). Three more curves are symmetrically generated by QRC (upper_midpt, lower_midpt, sum_min) from target and max. The values of target and max are specified by the user will dictate the shape of these curves.

The difference between sum_actual and sum_target (called 'bytediff') identifies the margin of error between the target and actual sizes. The difference between the current bytediff and the previously calculated bytediff represents the rate of change in this margin over time. The sign of this rate is used to identify if the correction is trending in the appropriate direction (towards bytediff = 0).

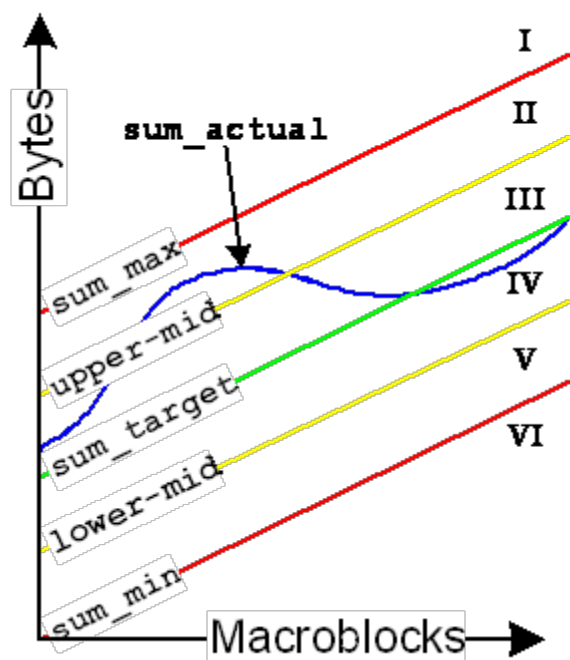

QPmod

Each macroblock will have a requested QP (which could vary across macroblocks or remain constant). QPmod is to be added to the QP requested. QPmod will be positive when the target was under-predicted and negative when the target is over-predicted.

QPmod is incremented or decremented when internal counters (called 'over' and 'under') reach tripping points (called 'grow' and 'shrink'). For each MB processed and based on which region (1-6) `sum_actual` falls in, various amounts of points are added to either counters. If over exceeds grow, QPmod is incremented whereas if under exceeds shrink, QPmod is decremented.

To dampen the effect of repeated changes in the same direction, an increase in resistance for that direction and decrease in resistance for the complementary direction occurs (called 'grow_resistance' and 'shrink_resistance'). This resistance is added to grow or shrink, which then requires more points to trip the next correction in that direction.

The user can specify guard-bands that limit the amount QPmod can be modified. QPmod cannot exceed `QPmax_pos_mod` or become less than `-QPmax_neg_mod_abs`.



Triggering

The RC unit begins to modify QPmod occurs only when it is triggered.

Three levels of triggering exist: always, gentle, loose. Always means that RC will be active once sum_actual reaches regions 3 or 4. Gentle will trigger RC once sum_actual reaches regions 2 or 5. Loose waits to trigger RC when sum_actual reaches regions 1 or 6.

RC will deactivate (triggered = false) once sum_actual begins to track sum_target over a series of macroblocks. Specifically, the sign of the rate of change for bytediff is monitored over a window of macroblocks. When the sum of these signs over the window falls within a tolerance value (called 'stable'), triggered will reset to false.

Panic

When enabled, panic mode will occur whenever sum_actual reaches region 1 and will remain so until sum_actual reaches region 4. When panicking, all macroblocks will be quantized with $QP = MB(n).QP + QP_{max_pos_mod}$, clamped to 51.

User Controls

This unit achieves a large flexibility by allowing the user to define various key parameters. At the per-macroblock level, the values of target and max are specified and will create various shapes of curves that sum_actual will be compared against.

Per-slice, the user can specify the triggering sensitivity and the tolerance required to disable the trigger. Additionally, the user can enable panic detection.

The point values assigned to each of the 6 regions are exposed to the user which allow for asymmetrical control for over and under predictions amongst other things. Additionally, the user can specify the initial values of grow and shrink along with the resistance values applied when correction is invoked.

Lastly, the maximum and minimum values for QPmod are also exposed to the user.



AVC Encoder MBAFF Support

1. Algorithm

Prediction of current macroblock motion vector is possible from neighboring macroblocks $mbAddrA/mbAddrD/mbAddrB/mbAddrC/mbAddrA+1/mbAddrD+1/mbAddrB+1/mbAddrC+1$. The selection of these macroblocks depends on coding type(field/frame) of current macroblock pair and the coding of neighbouring macroblock pair. Following is a generic diagram depicting naming conventions used for neighbouring macroblocks. Selection of these mb pairs described in detail in following sections.

1.1 Selection of Top LeftMB pair: The selection of Top Left MB pair depends on coding type of current and also top left macroblock pair. Following diagram shows the mapping to be used in MPC unit for the selection of the Top Left MB (D or D+1 macroblock).

1.2 Selection of LeftMB pair The selection of Left MB pair depends on coding type of current and also left macroblock pair. Following diagram shows the mapping to be used in MPC unit for the selection of the Left MB (A or A+1 macroblock).

1.3 Selection of Top MB pair The selection of Top MB pair depends on coding type of current and also top macroblock pair. Following diagram shows the mapping to be used in MPC unit for the selection of the Top MB (B or B+1 macroblock).

1.4 Selection of Top RightMB pair The selection of Top Right MB pair depends on coding type of current and also top right macroblock pair. Following diagram shows the mapping to be used in MPC unit for the selection of the Top Right MB (C or C+1 macroblock).

1.5 Motion Vector and refIdx Scaling Motion vectors and refence index of neighbouring macroblocks ($mbAddrA/mbAddrB/mbAddrC/mbAddrD$) should be scaled before using them into prediction equations. Again the scaling depends on coding type of current and neighbouring macroblock pair which is described as follows,

- If the current macroblock is a field macroblock and the macroblock $mbAddrN$ is a frame macroblock

$$mvLXN[1] = mvLXN[1] / 2 \quad (8-214)$$

$$refIdxLXN = refIdxLXN * 2 \quad (8-215)$$

- Otherwise, if the current macroblock is a frame macroblock and the macroblock $mbAddrN$ is a field macroblock

$$mvLXN[1] = mvLXN[1] * 2 \quad (8-216)$$

$$refIdxLXN = refIdxLXN / 2 \quad (8-217)$$

- Otherwise, the vertical motion vector component $mvLXN[1]$ and the reference index $refIdxLXN$ remain unchanged.



MPEG-2

This topic is currently under development.

MPEG2 Common Commands

MFx Commands are organized into groups based on their scope of functioning. There are Pipeline Common state commands that are common to all codecs (encoder and decoder) and is applicable to the processing of one full frame/field. There are also individual codec Common state commands that are common to both encoder and decoder of that particular codec. These latter common state commands, some are applicable at the processing of one full frame/field, and some are applicable at the processing of an individual slice level.

MFx_MPEG2_PIC_STATE



MPEG2 Decoder Commands

These are decoder-only commands. They provide the pointer to the compressed input bitstream to be decoded.

MFD_MPEG2_BSD_OBJECT

MFD_MPEG2_BSD_OBJECT Inline Data Description

Indirect Data Description

The indirect data start address in MFD_MPEG2_BSD_OBJECT specifies the starting Graphics Memory address of the bitstream data that follows the slice header. It provides the byte address for the first macroblock of the slice. Together with the First Macroblock Bit Offset field in the inline data, it provides the bit location of the macroblock within the compressed bitstream.

The indirect data length in MFD_MPEG2_BSD_OBJECT provides the length in bytes of the bitstream data for this slice. It includes the first byte of the first macroblock and the last **non-zero** byte of the last macroblock in the slice. Specifically, the zero-padding bytes (if present) and the next start-code are excluded. Hardware ignores the contents after the last non-zero byte. *Indirect Data Description* illustrates these parameters for a slice data.

Indirect data buffer for a slice

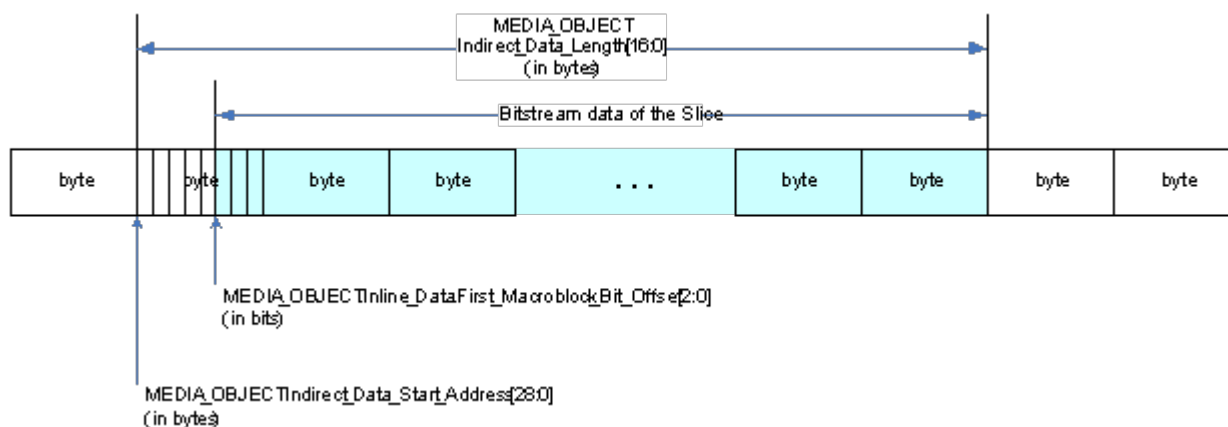



MPEG2 Encoder PAK Commands

This topic is currently under development.

The MFC_MPEG2_PAK_INSERT_OBJECT Command is identical to the MFC_AVC_PAK_INSERT_OBJECT command as described in this document.

The MFC_MPEG2_STITCH_OBJECT Command is identical as MFC_AVC_STITCH_OBJECT command as described in this document.

MFC_MPEG2_SLICEGROUP_STATE

MFC_MPEG2_PAK_OBJECT

PAK Object Inline Data Description – MPEG-2

The Inline Data includes all the required MB encoding states, constitute part of the Slice Data syntax elements, MB Header syntax elements and their derivatives. It provides information for the following operations:

1. Forward and Inverse Transform
2. Forward and Inverse Quantization
3. Advanced Rate Control (QRC)
4. MB Parameter Construction (MPC)
5. VLC encoding
6. Bit stream packing
7. Internal error handling

These state/parameter values may subject to change on a per-MB basis, and must be provided in each MFC_MPEG2_PAK_OBJECT command. The values set for these variables are retained internally, until they are reset by hardware Asynchronous Reset or changed by the next MFC_MPEG2_PAK_OBJECT command.

The inline data has been designed to match AVC MB structure for efficient transcoding.

Current MB [x,y] address is not sent, it is assumed that the H/W will keep track of the MB count and current MB position internally.



DWord	Bit	Description	Project	Security
1	31:27	Reserved: MBZ		
	22-20	<p>MvFormat (Motion Vector Size). This field specifies the size and format of the input motion vectors.</p> <p>This field is reserved (MBZ) when the IntraMbFlag = 1.</p> <p>The valid encodings are:</p> <p>011 = Unpacked: Two motion vector pairs</p> <p>Others are reserved.</p> <p><i>(The following encodings are intended for other formats:</i></p> <p><i>001 = 1MV: one 16x16 motion vector</i></p> <p><i>010 = 2MV: One 16x16 motion vector pair</i></p> <p><i>011 = 4MV: Four 8x8 motion vectors, or Two 16x8 motion vector pairs</i></p> <p><i>100 = 8MV: Four 8x8 motion vector pairs</i></p> <p><i>101 = 16MV: 16 4x4 motion vectors</i></p> <p><i>110 = 32MV: 16 4x4 motion vector pairs</i></p> <p><i>111 = Packed, number of MVs is given by packedMvNum.)</i></p>		
	19	CbpDcY. This field specifies if the Luma DC coded. Must be 1 for MPEG-2.		
	18	CbpDcU. This field specifies if the Chroma Cb DC coded. Must be 1 for MPEG-2.		
	17	CbpDcV. This field specifies if the Chroma Cb DC coded. Must be 1 for MPEG-2.		
	16	Reserved: MBZ		
	15	<p>TransformFlag</p> <p>Used to indicate transformation type for MPEG-2.</p> <p>0 = Frame DCT transformation</p> <p>1 = Field DCT transformation</p>		
14	<p>FieldMbFlag</p> <p>For MPEG-2, this flag is set to 1 if either the picture is in field type or the MB is INTER of field type, i.e. split into two 16x8 field blocks.</p>			



	13	<p>IntraMbFlag</p> <p>This field specifies whether the current macroblock is an Intra (I) macroblock. For I-picture MB (IntraPicFlag =1), this field must be set to 1.</p> <p>This flag must be set in consistent with the interpretation of MbType (inter or intra modes).</p> <p>0: INTER (inter macroblock) 1: INTRA (intra macroblock)</p>		
	12:8	<p>MbType</p> <p>This field is encoded to match with the best macroblock mode determined as described in the next section. It follows an unified encoding for inter and intra macroblocks according to MFX Encoding reference as shown in Figure A.</p>		
	7:3	Reserved : MBZ		
	2	<p>SkipMbFlag</p> <p>By setting it to 1, this field forces an inter macroblock to be encoded as a skipped macroblock. It is equivalent to mb_skip_flag in AVS spec, Hardware honors input MVs for motion prediction and forces CBP to zero.</p> <p>By setting it to 0, an inter macroblock will be coded as a normal inter macroblock. The macroblock may still be coded as a skipped macroblock, according to the macroblock type conversion rules described in the later sub sections.</p> <p>This field can only be set to 1 for certain values of MbType. See details later.</p> <p>This field is only valid for an inter macroblock. Hardware ignores this field for an intra macroblock.</p> <p>0 = not a skipped macroblock 1 = is coded as a skipped macroblock</p> <p>Note: When this flag is set to 1, the correct MVs are assumed for HW decoder to generate decoded reconstruction frame.</p>		
	1:0	<p>InterMbMode</p> <p>This field is provided to carry redundant information as that encoded in MbType. This field is only valid if IntraMbFlag =0, otherwise, it is ignored by hardware.</p>		
2	31:16	<p>MbYCnt (Vertical Origin). This field specifies the vertical origin of current macroblock in the destination picture in units of macroblocks.</p> <p>Format = U16 in unit of macroblock.</p>		
	15:0	<p>MbXCnt (Horizontal Origin). This field specifies the horizontal origin of current macroblock in the destination picture in units of macroblocks.</p> <p>Format = U16 in unit of macroblock.</p>		



3	31:24	MaxSizeInWord PAK should not exceed this budget accumulatively, otherwise it will trickle the PANIC mode.		
	23:16	TargetSizeInWord PAK should use this budget accumulatively to decide if it needs to limit the number of non-zero coefficients.		
	15:13	MBZ		
	12:0	Cbp – Coded Block Pattern. This field specifies whether blocks are present or not. Format = 6-bit mask (or 8-bit, & 12-bit, for 422 and 444). Bit 11: Y0Bit 10: Y1Bit 9: Y2Bit 8: Y3 Bit 7: Cb4Bit 6: Cr5Bits 0-5: MBZ		
4	31	LastMbInSlice – the last MB in a slice.		
	30	FirstMbInSlice – the first slice in a slice, it requires slice header insertion.		
	29:28	MBZ		
	27	EnableCoeffClamp 1 = the magnitude of coefficients of the current MB will be clamped based on the clamping matrix after quantization 0 = no clamping		
	26	LastMbInSG 1 – the current MB is the last MB in the current slice group.		
	25	MbSkipConvDisable This is a per-MB level control to enable and disable skip conversion. This field is ORed with SkipConvDisable field. This field is only valid for a P or B slice. It must be zero for other slice types. Rules are provided in <i>Macroblock Type Conversion Rules</i> 0 - Enable skip type conversion for the current macroblock 1 – Disable skip type conversion for the current macroblock		
	24	FirstMbInSG 1 – the current MB is the last MB in the current slice group.		
23:20	MBZ			



	19:16	<p>MvFieldSelect – Motion Vertical Field Select. A bit-wise representation of a long [2][2] array as defined in §6.3.17.2 of the <i>ISO/IEC 13818-2</i> (see also §7.6.4).</p> <table border="1"> <thead> <tr> <th>Bit</th> <th>MVector[r]</th> <th>MVector[s]</th> <th>MotionVerticalFieldSelect Index</th> </tr> </thead> <tbody> <tr> <td>16</td> <td>0</td> <td>0</td> <td>0</td> </tr> <tr> <td>17</td> <td>0</td> <td>1</td> <td>1</td> </tr> <tr> <td>18</td> <td>1</td> <td>0</td> <td>2</td> </tr> <tr> <td>19</td> <td>1</td> <td>1</td> <td>3</td> </tr> </tbody> </table> <p>Format = MC_MotionVerticalFieldSelect. 0 = The prediction is taken from the <i>top</i> reference field. 1 = The prediction is taken from the <i>bottom</i> reference field.</p>	Bit	MVector[r]	MVector[s]	MotionVerticalFieldSelect Index	16	0	0	0	17	0	1	1	18	1	0	2	19	1	1	3		
	Bit	MVector[r]	MVector[s]	MotionVerticalFieldSelect Index																				
	16	0	0	0																				
	17	0	1	1																				
18	1	0	2																					
19	1	1	3																					
15:5	MBZ Reserved																							
4:0	QpScaleCode																							
5	31:16	<p>MV[0][0].y – the y coordinate of the first forward MV if Mv[0][0] n/a: if Mv[1][0] available, it MUST be set to the same value as Mv[1][0]. else it MUST be set to the value 0</p>																						
	15:0	<p>MV[0][0].x – the x coordinate of the first forward MV if Mv[0][0] n/a: if Mv[1][0] available, it MUST be set to the same value as Mv[1][0]. else it MUST be set to the value 0</p>																						
6	31:0	<p>MV[1][0] – the first backward MV if Mv[1][0] n/a: it MUST be set to the same value as Mv[0][0]</p>																						
7	31:0	<p>MV[0][1] – the second forward MV if Mv[0][1] n/a: if Mv[1][1] available, it MUST be set to the same value as Mv[1][1]. else it MUST be set to the same value as Mv[0][0]</p>																						
8	31:0	<p>MV[1][1] – the second backward MV if Mv[1][1] n/a: it MUST be set to the same value as Mv[1][0]</p>																						

The mapping between MPEG-2 spec and MfxMbCode can be achieved according to the following:

1) Renamed variables with identical meaning:



MPEG-2 Spec	MXF API	Value
macroblock_quant	MbQuantPresent	0 or 1
macroblock_intra	IntraMbFlag	0 or 1
dct_type	Transform8x8Flag	0 or 1
macroblock_pattern	Cbp8x8	remapped

2) Macroblock type remapping:

		B-spec Entry					MPEG-2 Spec					
Frame Type	Mb Type	Intra Mb Flag	Skip Mb Flag	Mb Type 5Bits	Field Mb Flag	Inter Mb Mode	macroblock_intra	motion_type_bit0	motion_type_bit1	motion_forward	motion_backward	
IPB	Intra	1	0	1Ah	0/1	-	1	-	-	-	-	
P B B	Skip	0	1	01h	0/1	0	0	-	-	1	0	
				02h					0	1		
				03h					1	1		
P	0-MV*	0	0	01h	0/1	0	0	-	-	0	0	
P Frame	Frame type	0	0	01h	0	0	0	0	1	1	0	
P Frame	Field type	0	0	04h	1	1	0	1	0	1	0	
P Frame	dual prime	0	0	19h	0	0	0	1	1	1	0	
P Field	One 16x16	0	0	01h	1	0	0	1	0	1	0	
P	Two	0	0	04h	1	1	0	0	1	1	0	



		B-spec Entry					MPEG-2 Spec					
Frame Type	Mb Type	Intra Mb Flag	Skip Mb Flag	Mb Type 5Bits	Field Mb Flag	Inter Mb Mode	macroblock_intra	motion_type_bit0	motion_type_bit1	motion_forward	motion_backward	
Field	16x8											
P Field	dual prime	0	0	19h	1	0	0	1	1	1	0	
B Frame	Frame type	0	0	01h 02h 03h	0	0	0	0	1	1 0 1	0 1 1	
B Frame	Field type	0	0	04h 06h 14h	1	1	0	1	0	1 0 1	0 1 1	
B Field	One 16x16	0	0	01h 02h 03h	1	0	0	1	0	1 0 1	0 1 1	
B Field	Two 16x8	0	0	04h 06h 14h	1	1	0	0	1	1 0 1	0 1 1	

- Notice that there is no special way to indicate 0 motion vector case for P frame. It is for PAK to handle internally by checking up the motion vector values.
- Notice also, the MbType5bits is adapted from AVC DXVA macroblock types. It may seem awkward from MPEG-2 perspective, but provides a common VME interface for us for simpler HW design and help the advanced transcoding solution.



MFX HW Interface and DXVA Conversion

This topic is currently under development.

Map DXVA to HW PRM

		HW	
Location		PRM	
BYTE		MPEG-2	DXVA
	DW0		
0		MbMode	
0.0-1	0[0-1]	InterMbMode	see (A)
0.2	0[2]	SkipMbFlag	<-MBskipsFollowing
0.3	0[3]	mbz	
0.4-5	0[4-5]	IntraMbMode	IntraMacroblock
0.6	0[6]	mbz	
0.7	0[7]	FieldMbPolarity	derived
1		MbType	
1.0-4	0[8-12]	MbType5Bits	see (A)
1.5	0[13]	IntraMbFlag	IntraMacroblock
1.6	0[14]	FieldMbFlag	see (A)
1.7	0[15]	TransformFlag	FieldResidual
2		MbFlag	
2.0	0[16]	ResidDataFlag	HostResDiff
2.1	0[17]	CbpDcV	PAK control



2.2	0[18]	CbpDcU	PAK control
2.3	0[19]	CbpDcY	PAK control
2.4-6	0[20-22]	MvFormat	= 3, derived
2.7	0[23]	mbz	
3	0[24-31]	PackedMvNum	see (A)
	DW1		
4-5	1[0-15]	MbXCnt	wMAddress
6-7	1[16-31]	MbYCnt	wMAddress
	DW2		
8	2[0-7]		bNumCoef[0]
8.0-5	2[0-5]	mbz	
8.6-7	2[6-7]	CbpAcUV	PAK control
9	2[8-11]	CbpAcY	PAK control
	2[12-15]	mbz	
10	2[16-23]	TargetedSzInWord	
11	2[24-31]	MaxSzInWord	
	DW3		
12		Qscale	derived
12.0-6	3[0-6]	QScaleCode	
12.7	3[7]	QScaleType	
13	3[8-15]	mbz	



14	3[16-19]	MvFieldSelect	MvertFieldSel
	3[20-23]	mbz	
15		MbExtFlag	
15.0	3[24]	mbz	
15.1	3[25]	SkipMvConvDisable	
15.2	3[26]	LastMbFlag	PAK control
15.3	3[27]	EnableCoeffClamp	PAK control
15.4-5	3[28-29]	MbScanMethod	MBscanMethod
15.6	3[30]	NewSliceFlag	PAK control
15.7	3[31]	EndSliceFlag	PAK control
	DW4-7		
16-32	4-7[all]	MV[2][2][2]	MVector[4][2]

(A): Set **InterMbMode**, **MbType5bits**, **FieldMbFlag**, and **PackedMvNum** from DXVA parameters:

```
if(IntraMacroblock) return (TYPE_INTRA);
else if(MotionType==3){ // dual prime
    MbType5bits = 0x19;
    FieldMbFlag = 0;
    InterMbMode = 0;
    PackedMvNum = 2;
    return (DUAL_PRIME);
}
else{
    IsFieldFrame = a PicState derivative;
    switch(MotionType+IsFieldFrame{
    case 1: // Two 16x8 field in Frame Frame
    case 3: // Two 16x8 field in Field Frame
```



```
FieldMbFlag = 1;
InterMbMode= 1;
switch(MotionForward | Motionbackward <<1)) {
case 1:
    MbType5bits = 4;
    PackedMvNum = 2;
    break;
case 2:
    MbType5bits = 6;
    PackedMvNum = 2;
    break;
case 3:
    MbType5bits = 0x14;
    PackedMvNum = 4;
    break;
}
break;
case 2: // 16x16 block in either case
FieldMbFlag= IsFieldFrame;
InterMbMode= 0;
switch(MotionForward | (Motionbackward<<1)) {
case 1:
    MbType5bits = 1;
    PackedMvNum= 1;
    break;
case 2:
    MbType5bits = 2;
    PackedMvNum= 1;
    break;
case 3:
    MbType5bits = 3;
    PackedMvNum= 2;
    break;
}
```



```
        break;
    }
}
```

Map HW PRM to DXVA

	DXVA	PRM
		MPEG-2
0-1	wMBAaddress	= MbYCnt*MbW + MbXCnt
2-3	wMBtype	
2.0	IntraMacroblock	= IntraMbFlag
2.1	MotionForward	see (B)
2.2	MotionBackward	see (B)
2.3	Motion4MV	VC-1 only, MBZ for Mpeg-2
2.4	Reserved	
2.5	FieldResidual	= TranformFlag
2.6-7	MBscanMethod	= MbScanMethod
3.0-1	MotionType	see (B)
3.2	HostResDiff	= ResidDataFlag
3.3	Reserved	
3.4-7	MvertFieldSel	= MvFieldSelect
4	MBskipsFollowing	count SkipMbFlag
5-7	MBdataLocation	n/a
8-9	wPatternCode	= CbpAcY UV
10-15	bNumCoef[6]	n/a
16-32	MVector[4][2]	= MV[2][2][2]



(B): Set **MbType** and **MotionType** from PRM interface

```
if(MbIntraFlag) return (TYPE_INTRA);
else if(MbType5Bits&8){ // dual prime
    MotionForward= 1;
    MotionBackward= 0;
    MotionType= 3;
    return (DUAL_PRIME);
}
else{
    // redundant: InterMbMode = !(MbType5Bits&4);
    if(InterMbMode){
        MotionForward= !(MbType5Bits&2);
        MotionBackward= !(MbType5Bits&0x12);
    }
    else{
        MotionForward= (MbType5Bits&1);
        MotionBackward= !(MbType5Bits&2);
    }
    MotionType = 2-(InterMbMode^FieldMbFlag);
    // equivalently the 2 bits are:
    // MotionType0 = (InterMbMode^FieldMbFlag);
    // MotionType1 = ~MotionType0;
    return (TYPE_INTER);
}
```



JPEG and MJPEG

This topic is currently under development.

JPEG Decoder Commands

Following are JPEG Decoder Commands:

MFD_JPEG_BSD_OBJECT

For JPEG decoding, the following program note is informative.

For **Rotation**, it is important to note that rotation of 90 or 270 degrees also requires exchanging **FrameWidthInBlksMinus1** with **FrameHeightInBlksMinus1** in the command. In addition, the rotation of 90 or 270 degrees also requires transportation of the quantization matrix will be transposed into the position (y, x).

Chroma type is determined by the values of horizontal and vertical sampling factors of the components (H_i and V_i where i is a component id) in the Frame header as shown in the following table.

	H1	H2	H3	V1	V2	V3
0: YUV400	r	Not available	Not available	r	Not available	Not available
1: YUV420	2	1	1	2	1	1
2: YUV422H_2Y	2	1	1	1	1	1
3: YUV444	1	1	1	1	1	1
4: YUV411	4	1	1	1	1	1
5: YUV422V_2Y	1	1	1	2	1	1
6: YUV422H_4Y	2	1	1	2	2	2
7: YUV422V_4Y	2	2	2	2	1	1

For YUV400, the value of $V1$ can be 1, 2, or 3 and will be same as the value of $H1$, and the Minimum coded unit (MCU) is one 8x8 block. For the other chroma formats, if non-interleaved data, the MCU is one 8x8 block. For interleaved data, the MCU is the sequence of block units defined by the sampling factors of the components.



For example, the following figures show the MCU structures of interleaved data and the decoding order of blocks in the MCU:

422H_2Y

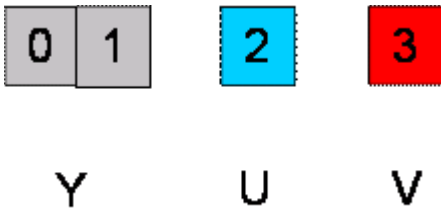

422H_4Y

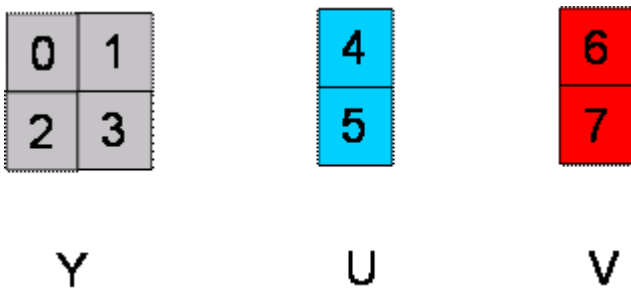

422V_2Y

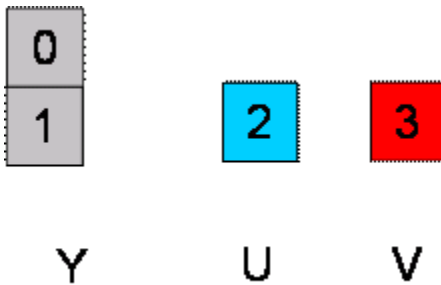

422V_4Y

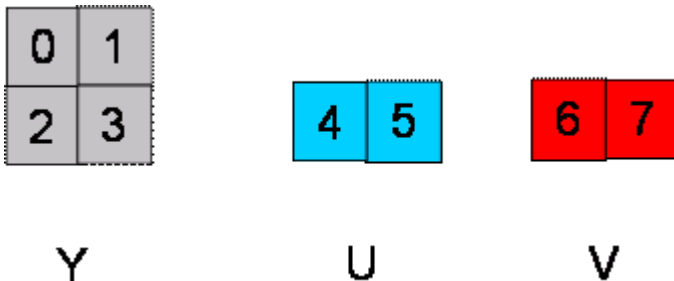

If picture width X in the Frame header is not a multiple of 8, the decoding process needs to extend the number of columns to complete the right-most sample blocks. If the component is to be interleaved, the decoding process needs to extend the number of samples by one or more additional blocks so that the number of blocks is an integer multiple of H_i . In other words, "The number of blocks in width" in the table should be an integer multiple of $(8 \times H_i)$. Similarly, if picture height Y in the Frame header is not a

multiple of 8, the decoding process needs to extend the number of lines to complete bottom-most block-row. If the component is to be interleaved, the decoding process also needs to extend the number of lines by one or more additional block-rows so that the number of block-row is an integer multiple of $(8 \times V1)$. For example, if non-interleaved YUV411 with $X=270$, then "The number of blocks in width" shall be $(270 + 7) / 8 = 34$, where "/" is integer division. Therefore, **FrameWidthInBlksMinus1** is set to 33. However, for interleaved data, "The number of blocks in width" shall be $((270 + 31) / 32) \times 4 = 36$. Therefore, **FrameWidthInBlksMinus1** is set to 35.

The following description applies only to [DevHSW+, EXCLUDE(DevHSW:GT3:A, DevHSW:GT3:B, DevHSW:GT2:B)]:

VertUpSamplingEnb is used to convert an input chroma420 to an output chroma422 in the surface format of YUY2 or UYVY. To enable this flag, the input should be interleaved Scan, InputFormatYUV should be set to YUV420, and OutputFormatYUV should be set to YUY2 or UYVY. Vertical 2:1 up-sampling is only applied to chroma blocks where each line of 8×8 block pixels is replicated to make 8×16 U/V blocks. For example:

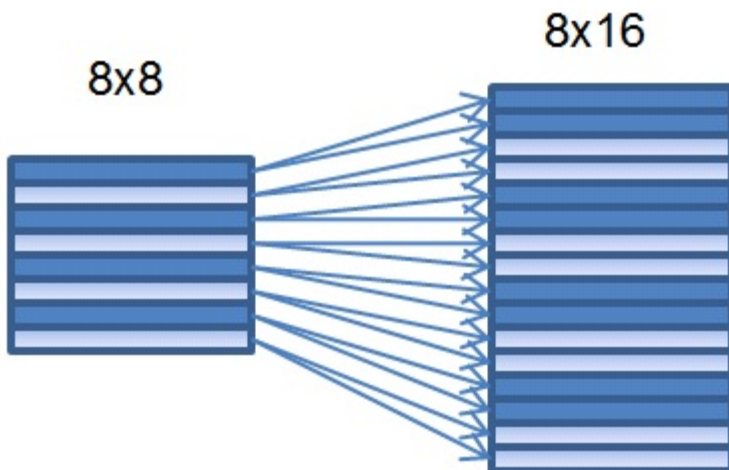

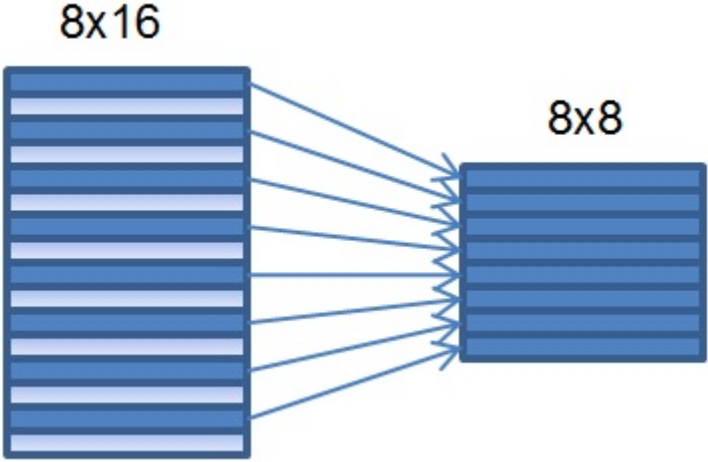
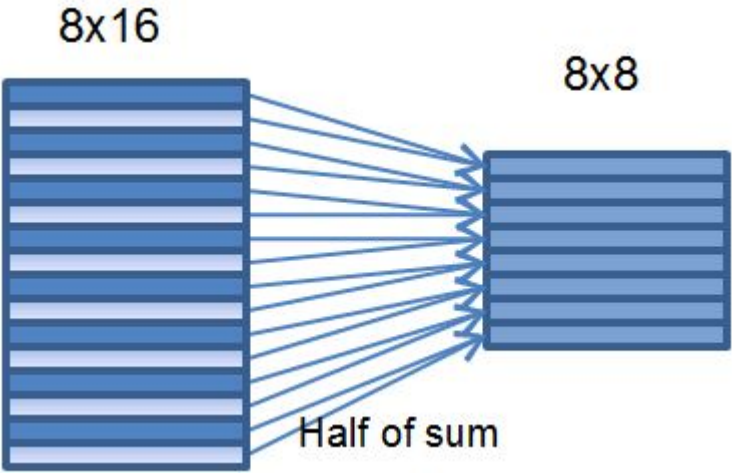

VertDownSamplingEnb is used to convert an input chroma422 to an output chroma420 in the surface format NV12. To enable this flag, the input should be interleaved Scan, InputFormatYUV should be set to YUV422H_2Y or YUV422H_4Y, and OutputFormatYUV should be set to NV12. Combined with AvgDownSampling flag, the following table and figures show the down-sampling methods.

VertDownSamplingEnb	AvgDownSampling	Down-Sampling Methods
0	0 or 1	No down-sampling.
1	0	Drop every other line: 
1	1	Average vertically neighboring two pixels: 



Revision history for PRM commands is described in the following:

-

Project:	HSW
On HSW-A, and HSW-B, there is no change for the JPEG Format support.	

- If the InputFormat is YUV400 or YUV444 or YUV411, then output cannot be NV12, YUY2 or UYVY, it has to be planar. But for 420 and 422 InputFormat, there's a choice of having Planar, NV12, YUY2 or UYVY OutputFormat. And the surface state should be programmed accordingly.
- Refer "Output Format YUV" field for more details.

MFJ_JPEG_HUFF_TABLE_STATE



More Decoder and Encoder

This topic is currently under development.

MFD IT Mode Decode Commands

These are decoder-only commands to support the IT-mode specified in DXVA interface.

MFD_IT_OBJECT

Common Indirect IT-COEFF Data Structure

Transform-domain residual data block in AVC-IT, VC1-IT and MPEG2-IT mode follows the same data structure.

The indirect IT-COEFF data start address in MFD_IT_OBJECT command specifies the doubleword aligned address of the first non-zero DCT coefficient of the first block of the macroblock. Only the non-zero coefficients are present in the data buffer and they are packed in the 8x8 block sequence of Y0, Y1, Y2, Y3, Cb4 and Cr5, as shown in *Common Indirect IT-COEFF Data Structure*. When an 8x8 block is further subdivided into 4x4 subblocks, the coefficients, if present, are organized in the subblock order. The smallest subblock division is referred to as a **transform block**. The indirect IT-COEFF data length in the command includes all the non-zero coefficients for the macroblock. It must be doubleword aligned.

Structure of the IDCT Compressed Data Buffer

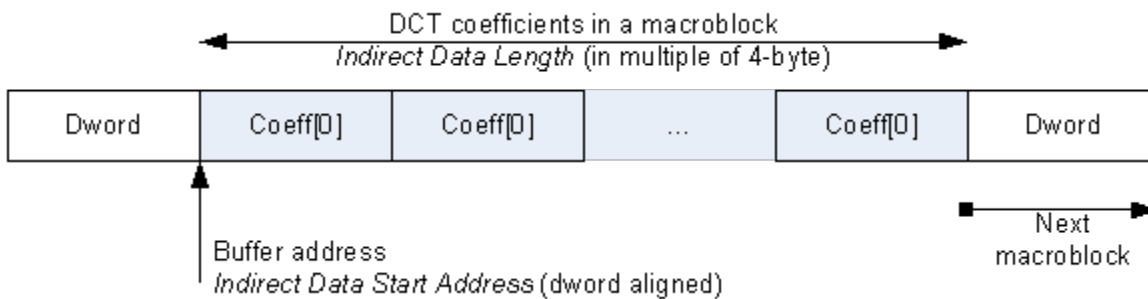

Each non-zero coefficient in the indirect data buffer is contained in a doubleword-size data structure consisting of the coefficient index, end of block (EOB) flag and the fixed-point coefficient value in 2's complement form. As shown in *Common Indirect IT-COEFF Data Structure*, *index* is the row major 'raster' index of the coefficient **within a transform block** (please note that it is not converted to 8x8 block basis). A coefficient is a 16-bit value in 2's complement.



Structure of a transform-domain residue unit

DWord	Bit	Description
0	31:16	Transform-Domain Residual (coefficient) Value. This field contains the value of the non-zero transform-domain residual data in 2's compliment.
	15:7	Reserved: MBZ
	6:1	Index. This field specifies the raster-scan address (raw address) of the coefficient within the transform block. For a coefficient at Cartesian location (row, column) = (y, x) in a transform block of width W, Index is equal to (y * W + x). For example, coefficient at location (row, column) = (0, 0) in a 4x4 transform block has an index of 0; that at (2, 3) has an index of $2*4 + 3 = 11$. The valid range of this field depends on the size of the transform block. Format = U6 Range = [0, 63]
	0	EOB (End of Block). This field indicates whether the transform-domain residue is the last one of the current transform block.

Allowed transform block dimensions per coding standard

Transform Block Dimension	AVC	VC1	MPEG2
8x8	Yes	Yes	Yes
8x4	No	Yes	No
4x8	No	Yes	No
4x4	Yes	Yes	No

For AVC, there is intra16x16 mode, in which the DC Luma coefficients of all 4x4 sub-blocks within the current MB are sent separately in its own 4x4 Luma block. As such, only 15 coefficients remains in each of the 16 4x4 Luma blocks.



Inline Data Description in AVC-IT Mode

The Inline Data includes all the required MB decoding states, extracted primarily from the Slice Data, MB Header and their derivatives. It provides information for the following operations:

1. Inverse Quantization
2. Inverse Transform
3. Intra and inter-Prediction decoding operations
4. Internal error handling

IT Mode supports only packed MV data as specified in the DXVA spec.

These state/parameter values may subject to change on a per-MB basis, and must be provided in each MFD_IT_OBJECT command. The values set for these variables are retained internally, until they are reset by hardware Asynchronous Reset or changed by the next MFC_AVC_PAK_OBJECT command.

The inline data has been designed to match the DXVA 2.0, with the exception of the starting byte (DW0:0-7) and the ending dword (DW7:0-31).

The Deblocker Filter Control flags (FilterInternalEdgesFlag, FilterTopMbEdgeFlag and FilterLeftMbEdgesFlag) are generated by H/W, which are depending on MbaffFrameFlag, CurrMbAddr, PicWidthInMbs and disable_deblocking_filter_idc states.

Current MB [x,y] address is not sent, it is assumed that the H/W will keep track of the MB count and current MB position internally.

DWord	Bit	Description
0	31:24	<p>MvQuantity</p> <p>Specify the number of MVs (in unit of motion vector, 4 bytes each) to be fetched for motion compensation operation.</p> <p>Decoder IT mode only supports packed MV format (DXVA). This field specifies the exact number of MVs present for the current MB.</p> <p>For a P-Skip MB, there is still 1 MV being sent (Skip MV is sent explicitly); for a B-Direct/Skip MB, there are 2 MVs being sent.</p> <p>For an Intra-MB, MvQuantity is set to 0.</p> <p>MvQuantity = 0, signifies there is no MV indirect data for the current MB.</p> <p>This field must be set in consistent with Indirect MV Data Length, so as not to exceed its bound Unsigned.</p>
	23:20	Reserved MBZ (DXVA)
	19	<p>DcBlockCodedYFlag</p> <p>1 – the 4x4 DC-only Luma sub-block of the Intra16x16 coded MB is present; it is still possible that all DC coefficients are zero.</p>

DWord	Bit	Description
		0 – no 4x4 DC-only Luma sub-block is present; either not in Intra16x16 MB mode or all DC coefficients are zero.
	18	<p>DcBlockCodedCbFlag</p> <p>For 4:2:0 case :</p> <p>1 – the 2x2 DC-only Chroma Cb sub-block of all coded MB (any type) is present; it is still possible that all DC coefficients are zero.</p> <p>0 – no 2x2 DC-only Chroma Cb sub-block is present; all DC coefficients are zero.</p>
	17	<p>DcBlockCodedCrFlag</p> <p>For 4:2:0 case :</p> <p>1 – the 2x2 DC-only Chroma Cr sub-block of all coded MB (any type) is present; it is still possible that all DC coefficients are zero.</p> <p>0 – no 2x2 DC-only Chroma Cr sub-block is present; all DC coefficients are zero.</p>
	16	Reserved MBZ (DXVA)
	15	<p>Transform8x8Flag</p> <p>0: indicates the current MB is coded with 4x4 transform and therefore the luma residuals are presented in 4x4 blocks.</p> <p>1: indicates the current MB is coded with 8x8 transform and therefore the luma residuals are presented in 8x8 blocks.</p> <p>Same as the transform_size_8x8_flag syntax element in AVC spec.</p>
	14	<p>MbFieldFlag</p> <p>This field specifies whether current macroblock is coded as a field or frame macroblock in MBAFF mode.</p> <p>1 = Field macroblock</p> <p>0 = Frame macroblock</p> <p>This field is exactly the same as FIELD_PIC_FLAG syntax element in non-MBAFF mode.</p> <p>Same as the mb_field_decoding_flag syntax element in AVC spec.</p>
	13	<p>IntraMbFlag</p> <p>This field specifies whether the current macroblock is an Intra (I) macroblock.</p> <p>0 – not an intra MB</p> <p>1 – is an intra MB</p> <p>I_PCM is considered as Intra MB.</p>



DWord	Bit	Description																								
		For I-picture MB (IntraPicFlag =1), this field must set to 1. This flag must be set in consistent with the interpretation of MbType (inter or intra modes).																								
	12:8	<p>MbType</p> <p>This field carries the Macroblock Type. The meaning depends on IntraMbFlag.</p> <p>If IntraMbFlag is 1, this field is the intra macroblock type as defined in <i>Macroblock Type for Intra Cases</i>.</p> <p>If IntraMbFlag is 0, this field is the inter macroblock type as defined in the first two columns of <i>Macroblock Type for Inter Cases</i>. All macroblock types in a P Slice are mapped into the corresponding types in a B Slice. Skip and Direct modes are converted into its corresponding processing modes.</p> <p>Programming note: It is exactly matched with that of DXVA 2.0.</p>																								
	7	<p>FieldMbPolarityFlag</p> <p>This field indicates the field polarity of the current macroblock.</p> <p>Within a MbAff frame picture, this field may be different per macroblock and is set to 1 only for the second macroblock in a MbAff pair if FieldMbFlag is set. Otherwise, it is set to 0.</p> <p>Within a field picture, this field is set to 1 if the current picture is the bottom field picture. Otherwise, it is set to 0. It is a constant for the whole field picture.</p> <p>This field is only valid for MBAFF frame picture. It is reserved and set to 0 for a progressive frame picture or a field picture.</p> <p>0 = Current macroblock is a field macroblock from the top field (first in a MBAFF pair) 1 = Current macroblock is a field macroblock from the bottom field (second in a MBAFF pair)</p>																								
	6	<p>IsLastMB</p> <p>1 – the current MB is the last MB in the current Slice 0 – the current MB is not the last MB in the current Slice</p>																								
	5-4	Reserved MBZ (Intel encoder)																								
	3:0	Reserved MBZ (DXVA Decoder)																								
1	31:16	<p>CbpY[bit 15:0] (Coded Block Pattern Y)</p> <p>For 4x4 sub-block (when Transform8x8flag = 0 or in intra16x16) :</p> <p>16-bit cbp, one bit for each 4x4 Luma sub-block (not including the DC 4x4 Luma block in intra16x16) in a MB. The 4x4 Luma sub-blocks are numbered as</p> <table border="1" data-bbox="326 1797 751 1934"> <tbody> <tr> <td>blk0</td> <td>1</td> <td>4</td> <td>5</td> <td>bit15</td> <td>14</td> <td>11</td> <td>10</td> </tr> <tr> <td>blk2</td> <td>3</td> <td>6</td> <td>7</td> <td>bit13</td> <td>12</td> <td>9</td> <td>8</td> </tr> <tr> <td>blk8</td> <td>9</td> <td>12</td> <td>13</td> <td>bit7</td> <td>6</td> <td>3</td> <td>2</td> </tr> </tbody> </table>	blk0	1	4	5	bit15	14	11	10	blk2	3	6	7	bit13	12	9	8	blk8	9	12	13	bit7	6	3	2
blk0	1	4	5	bit15	14	11	10																			
blk2	3	6	7	bit13	12	9	8																			
blk8	9	12	13	bit7	6	3	2																			



DWord	Bit	Description																
		<table border="1"> <tr> <td>blk10</td> <td>11</td> <td>14</td> <td>15</td> <td>bit 5</td> <td>4</td> <td>1</td> <td>0</td> </tr> </table> <p>The cbpY bit assignment is cbpY bit [15 – X] for sub-block_num X.</p> <p>For 8x8 block (when Transform8x8flag = 1)</p> <p>Only the lower 4 bits [3:0] are valid; the remaining upper bits [15:4] are ignored. The 8x8 Luma blocks are numbered as</p> <table border="1"> <tr> <td>blk0</td> <td>1</td> <td>bit3</td> <td>2</td> </tr> <tr> <td>blk2</td> <td>3</td> <td>bit1</td> <td>0</td> </tr> </table> <p>The cbpY bit assignment is cbpY bit [3 – X] for block_num X.</p> <p>0 in a bit – indicates the corresponding 8x8 block or 4x4 sub-block is not present (because all coefficient values are zero)</p> <p>1 in a bit – indicates the corresponding 8x8 block or 4x4 sub-block is present (although it is still possible to have all its coefficients be zero – bad coding).</p>	blk10	11	14	15	bit 5	4	1	0	blk0	1	bit3	2	blk2	3	bit1	0
blk10	11	14	15	bit 5	4	1	0											
blk0	1	bit3	2															
blk2	3	bit1	0															
	15:8	<p>VertOrigin (Vertical Origin). This field specifies the vertical origin of current macroblock in the destination picture in units of macroblocks.</p> <p>For field macroblock pair in MBAFF frame, the vertical origins for both macroblocks should be set as if they were located in corresponding field pictures. For example, for field macroblock pair originated at (16, 64) pixel location in an MBAFF frame picture, the Vertical Origin for both macroblocks should be set as 2 (macroblocks). Whether the current macroblock is the first/second (top/bottom) in a MBAFF pair is specified by FieldMbPolarityFlag.</p> <p>The macroblocks with (VertOrigin, HorzOrigin) must be delivered in the strict order as coded in the bitstream (raster order for progressive frame or field pictures and MBAFF pair order for MBAFF pictures). No gap is allowed. Otherwise, hardware behavior is undefined.</p> <p>Format = U8 in unit of macroblock.</p>																
	7:0	<p>HorzOrigin (Horizontal Origin). This field specifies the horizontal origin of current macroblock in the destination picture in units of macroblocks.</p> <p>Format = U8 in unit of macroblock.</p>																
2	31:16	<p>CbpCr (Coded Block Pattern Cr 4:2:0-only)</p> <p>Only the lower 4 bits [3:0] are valid; the remaining upper bits [15:4] are ignored (only valid for 4:2:2 and 4:4:4). The 4x4 Chroma Cr sub-blocks are numbered as</p> <table border="1"> <tr> <td>blk0</td> <td>1</td> <td>bit3</td> <td>2</td> </tr> <tr> <td>blk2</td> <td>3</td> <td>bit1</td> <td>0</td> </tr> </table> <p>The cbpCr bit assignment is cbpCr bit [3 – X] for sub-block_num X.</p> <p>0 in a bit – indicates the corresponding 4x4 sub-block is not present (because all coefficient values are zero)</p>	blk0	1	bit3	2	blk2	3	bit1	0								
blk0	1	bit3	2															
blk2	3	bit1	0															



DWord	Bit	Description								
		<p>1 in a bit – indicates the corresponding 4x4 sub-block is present (although it is still possible to have all its coefficients be zero – bad coding).</p> <p>For monochrome, this field is ignored.</p>								
	15-0	<p>CbpCb (Coded Block Pattern Cb 4:2:0-only)</p> <p>Only the lower 4 bits [3:0] are valid; the remaining upper bits [15:4] are ignored (only valid for 4:2:2 and 4:4:4). The 4x4 Chroma Cb sub-blocks are numbered as</p> <table border="1" style="margin-left: 20px;"> <tr> <td>blk0</td> <td>1</td> <td>bit3</td> <td>2</td> </tr> <tr> <td>blk2</td> <td>3</td> <td>bit1</td> <td>0</td> </tr> </table> <p>The cbpCb bit assignment is cbpCb bit [3 – X] for sub-block_num X.</p> <p>0 in a bit – indicates the corresponding 4x4 sub-block is not present (because all coefficient values are zero)</p> <p>1 in a bit – indicates the corresponding 4x4 sub-block is present (although it is still possible to have all its coefficients be zero – bad coding).</p> <p>For monochrome, this field is ignored.</p>	blk0	1	bit3	2	blk2	3	bit1	0
blk0	1	bit3	2							
blk2	3	bit1	0							
3	31:24	Reserved MBz								
	23:16	<p>QpPrimeCr</p> <p>Driver is responsible for deriving the QpPrimeCr from QpPrimeY.</p> <p>For 8-bit pixel data, QpCr is the same as QpPrimeCr, and it takes on a value in the range of 0 to 51, positive integer.</p>								
	15:8	<p>QpPrimeCb</p> <p>Driver is responsible for deriving the QpPrimeCb from QpPrimeY.</p> <p>For 8-bit pixel data, QpCb is the same as QpPrimeCb, and it takes on a value in the range of 0 to 51, positive integer.</p>								
	7:0	<p>QpPrimeY</p> <p>This is the per-MB QP value specified for the current MB.</p> <p>For 8-bit pixel data, QpY is the same as QpPrimeY, and it takes on a value in the range of 0 to 51, positive integer.</p>								
4 to 6	31:0 Each	<p>For intra macroblocks, definition of these fields are specified in Inline data subfields for an Intra Macroblock</p> <p>For inter macroblocks, definition of these fields are specified in Inline data subfields for an Inter Macroblock</p>								



Indirect Data Format in AVC-IT Mode

Indirect data in AVC-IT mode consist of Motion Vectors, Transform-domain Residue (Coefficient) and ILDB control data. All three data records have variable size. Size of each Motion Vector record is determined by the MvQuantity value as shown in *Indirect Data Format in AVC-IT Mode*. ILDB control record is fixed at the same size for all MBs in a picture. Coefficient data record is variable size per MB, since it may only consist of non-zero coefficients.

Each MV is represented in 4 bytes, in the form of

- Lower 2 bytes : horizontal MVx component in q-pel units
- Upper 2 bytes : vertical MVy component in q-pel units
- Integer distance is measured in unit of samples in the frame or field grid position.
- Chroma MVs are not sent and are derived in the H/W.



Indirect MV record size in AVC-IT mode

Macroblock Type	MVQuant
<i>BP_L0_16x16</i>	1
B_L1_16x16	1
B_Bi_16x16	2
<i>BP_L0_L0_16x8</i>	2
<i>BP_L0_L0_8x16</i>	2
B_L1_L1_16x8	2
B_L1_L1_8x16	2
B_L0_L1_16x8	2
B_L0_L1_8x16	2
B_L1_L0_16x8	2
B_L1_L0_8x16	2
B_L0_Bi_16x8	3
B_L0_Bi_8x16	3
B_L1_Bi_16x8	3
B_L1_Bi_8x16	3
B_Bi_L0_16x8	3
B_Bi_L0_8x16	3
B_Bi_L1_16x8	3
B_Bi_L1_8x16	3
B_Bi_Bi_16x8	4
B_Bi_Bi_8x16	4



Macroblock Type	MVQuant
BP_8x8	Sum

For macroblock type of BP_8x8, MvQuant takes the sum of value MvQ[i] of the four individual 8x8 sub macroblocks.

SubMbShape[i]	SubMbPredMode[i]	Description	MvQ[i]
0	0	BP_LO_8x8	1
0	1	B_L1_8x8	1
0	2	B_BI_8x8	2
1	0	BP_LO_8x4	2
1	1	B_L1_8x4	2
1	2	B_BI_8x4	4
2	0	BP_LO_4x8	2
2	1	B_L1_4x8	2
2	2	B_BI_4x8	4
3	0	BP_LO_4x4	4
3	1	B_L1_4x4	4
3	2	B_BI_4x4	8



Indirect data Deblocking Filter Control block in AVC-IT mode:

AVC Deblocker Control Data record has a fixed size for each MB in a picture and is 48 bytes or 12 Dwords in size.

DWord	Bit	Description
0	31:24	Reserved : MBZ (DXVA Decoder)
	23	FilterTopMbEdgeFlag
	22	FilterLeftMbEdgeFlag
	21	FilterInternal4x4EdgesFlag
	20	FilterInternal8x8EdgesFlag
	19	FieldModeAboveMbFlag
	18	FieldModeLeftMbFlag
	17	FieldModeCurrentMbFlag
	16	MbaffFrameFlag (DXVA Decoder reserved bit)
	15:8	VertOrigin Current MB y position (address)
	7:0	HorzOrigin Current MB x position (address)
1	31:30	bS_h13 2-bit boundary strength for internal top horiz 4-pixel edge 3
	29:28	bS_h12 2-bit boundary strength for internal top horiz 4-pixel edge 2
	27:26	bS_h11 2-bit boundary strength for internal top horiz 4-pixel edge 1
	25:24	bS_h10 2-bit boundary strength for internal top horiz 4-pixel edge 0
	23:22	bS_v33 2-bit boundary strength for internal right vert 4-pixel edge 3
	21:20	bS_v23 2-bit boundary strength for internal right vert 4-pixel edge 2
	19:18	bS_v13 2-bit boundary strength for internal right vert 4-pixel edge 1
	17:16	bS_v03 2-bit boundary strength for internal right vert 4-pixel edge 0



DWord	Bit	Description
	15:14	bS_v32 2-bit boundary strength for internal mid vert 4-pixel edge 3
	13:12	bS_v22 2-bit boundary strength for internal mid vert 4-pixel edge 2
	11:10	bS_v12 2-bit boundary strength for internal mid vert 4-pixel edge 1
	9:8	bS_v02 2-bit boundary strength for internal mid vert 4-pixel edge 0
	7:6	bS_v31 2-bit boundary strength for internal left vert 4-pixel edge 3
	5:4	bS_v21 2-bit boundary strength for internal left vert 4-pixel edge 2
	3:2	bS_v11 2-bit boundary strength for internal left vert 4-pixel edge 1
	1:0	bS_v01 2-bit boundary strength for internal left vert 4-pixel edge 0
2	31:28	bS_v30_0 4-bit boundary strength for Left0 4-pixel edge 3 (MSbit is wasted)
	17:24	bS_v20_0 4-bit boundary strength for Left0 4-pixel edge 2 (MSbit is wasted)
	23:20	bS_v10_0 4-bit boundary strength for Left0 4-pixel edge 1 (MSbit is wasted)
	19:16	bS_v00_0 4-bit boundary strength for Left0 4-pixel edge 0 (MSbit is wasted)
	15:14	bS_h33 2-bit boundary strength for internal bot horiz 4-pixel edge 3
	13:12	bS_h32 2-bit boundary strength for internal bot horiz 4-pixel edge 2
	11:10	bS_h31 2-bit boundary strength for internal bot horiz 4-pixel edge 1
	9:8	bS_h30 2-bit boundary strength for internal bot horiz 4-pixel edge 0
	7:6	bS_h23 2-bit boundary strength for internal mid horiz 4-pixel edge 3
	5:4	bS_h22 2-bit boundary strength for internal mid horiz 4-pixel edge 2
	3:2	bS_h21 2-bit boundary strength for internal mid horiz 4-pixel edge 1
	1:0	bS_h20 2-bit boundary strength for internal mid horiz 4-pixel edge 0
3	31:28	bS_h03_0 4-bit boundary strength for Top0 4-pixel edge 3 (MSbit is wasted)



DWord	Bit	Description
	27:24	bS_h02_0 4-bit boundary strength for Top0 4-pixel edge 2 (MSbit is wasted)
	23:20	bS_h01_0 4-bit boundary strength for Top0 4-pixel edge 1 (MSbit is wasted)
	19:16	bS_h00_0 4-bit boundary strength for Top0 4-pixel edge 0 (MSbit is wasted)
	15:12	bS_v03 4-bit boundary strength for Left1 4-pixel edge 3 (MSbit is wasted)
	11:8	bS_v02 4-bit boundary strength for Left1 4-pixel edge 2 (MSbit is wasted)
	7:4	bS_v01 4-bit boundary strength for Left1 4-pixel edge 1 (MSbit is wasted)
	3:0	bS_v00 4-bit boundary strength for Left1 4-pixel edge 0 (MSbit is wasted)
4	31:24	bIndexBinternal_Y Internal index B for Y
	23:16	bIndexAinternal_Y Internal index A for Y
	15:12	bS_h03_1 4-bit boundary strength for Top1 4-pixel edge 3 (MSbit is wasted)
	11:8	bS_h02_1 4-bit boundary strength for Top1 4-pixel edge 2 (MSbit is wasted)
	7:4	bS_h01_1 4-bit boundary strength for Top1 4-pixel edge 1 (MSbit is wasted)
	3:0	bS_h00_1 4-bit boundary strength for Top1 4-pixel edge 0 (MSbit is wasted)
5	31:24	bIndexBleft1_Y
	23:16	bIndexAleft1_Y
	15:8	bIndexBleft0_Y
	7:0	bIndexAleft0_Y
6	31:24	bIndexBtop1_Y
	23:16	bIndexAtop1_Y
	15:8	bIndexBtop0_Y
	7:0	bIndexAtop0_Y



DWord	Bit	Description
7	31:24	bIndexBleft0_Cb
	23:16	bIndexAleft0_Cb
	15:8	bIndexBinternal_Cb
	7:0	bIndexAinternal_Cb
8	31:24	bIndexBtop0_Cb
	23:16	bIndexAtop0_Cb
	15:8	bIndexBleft1_Cb
	7:0	bIndexAleft1_Cb
9	31:24	bIndexBinternal_Cr
	23:16	bIndexAinternal_Cr
	15:8	bIndexBtop1_Cb
	7:0	bIndexAtop1_Cb
10	31:24	bIndexBleft1_Cr
	23:16	bIndexAleft1_Cr
	15:8	bIndexBleft0_Cr
	7:0	bIndexAleft0_Cr
11	31:24	bIndexBtop1_Cr
	23:16	bIndexAtop1_Cr
	15:8	bIndexBtop0_Cr
	7:0	bIndexAtop0_Cr



Inline Data Description in VC1-IT Mode

DWord	Bits	Description										
+0	31:28	<p>MvFieldSelect. A bit-wise representation indicating which field in the reference frame is used as the reference field for current field. It's only used in decoding interlaced pictures.</p> <p>This field is valid for non-intra macroblock only.</p> <table border="1"> <thead> <tr> <th>Bit</th> <th>Description</th> </tr> </thead> <tbody> <tr> <td>28</td> <td>Forward predict of current frame/field or TOP field of interlace frame, or block 0 in 4MV mode.</td> </tr> <tr> <td>29</td> <td>Backward predict of current frame/field or TOP field of interlace frame, or forward predict for block 1 in 4MV mode.</td> </tr> <tr> <td>30</td> <td>Forward predict of BOTTOM field of interlace frame, or block 2 in 4MV mode.</td> </tr> <tr> <td>31</td> <td>Backward predict of BOTTOM field of interlace frame, or forward predict for block 3 in 4MV mode.</td> </tr> </tbody> </table> <p>Each corresponding bit has the following indication.</p> <p>0 = The prediction is taken from the <u>top</u> reference field.</p> <p>1 = The prediction is taken from the <u>bottom</u> reference field.</p>	Bit	Description	28	Forward predict of current frame/field or TOP field of interlace frame, or block 0 in 4MV mode.	29	Backward predict of current frame/field or TOP field of interlace frame, or forward predict for block 1 in 4MV mode.	30	Forward predict of BOTTOM field of interlace frame, or block 2 in 4MV mode.	31	Backward predict of BOTTOM field of interlace frame, or forward predict for block 3 in 4MV mode.
Bit	Description											
28	Forward predict of current frame/field or TOP field of interlace frame, or block 0 in 4MV mode.											
29	Backward predict of current frame/field or TOP field of interlace frame, or forward predict for block 1 in 4MV mode.											
30	Forward predict of BOTTOM field of interlace frame, or block 2 in 4MV mode.											
31	Backward predict of BOTTOM field of interlace frame, or forward predict for block 3 in 4MV mode.											
	27	Reserved. MBZ										
	26	<p>MvFieldSelectChroma . This field specifies the polarity of reference field for chroma blocks when their motion vector is derived in Motion4MV mode for interlaced (field) picture.</p> <p>Non-intra macroblock only. This field is derived from MvFieldSelect.</p> <p>0 = The prediction is taken from the <u>top</u> reference field.</p> <p>1 = The prediction is taken from the <u>bottom</u> reference field.</p>										
	25:24	<p>MotionType – Motion Type</p> <p>For frame picture, a macroblock may only be either 00 or 10.</p> <p>For interlace picture, a macroblock may be of any motion types. It can be 01 if and only if DctType is 1.</p> <p>This field is 00 if and only if IntraMacroblock is 1.</p> <p>00 = Intra</p> <p>01 = Field Motion.</p> <p>10 = Frame Motion or no motion.</p> <p>Others = Reserved.</p>										



DWord	Bits	Description
	23	Reserved. MBZ
	22	<p>MvSwitch. This field specifies whether the prediction needs to be switched from forward to backward or vice versa for single directional prediction for top and bottom fields of interlace frame B macroblocks.</p> <p>0 = No directional prediction switch from top field to bottom field 1 = Switch directional prediction from top field to bottom field</p>
	21	<p>DctType. This field specifies whether the residual data is coded as field residual or frame residual for interlaced picture. This field can be 1 only if MotionType is 00 (intra) or 01 (field motion).</p> <p>For progressive picture, this field must be set to '0', i.e. all macroblocks are frame macroblock.</p> <p>0 = Frame residual type. 1 = Field residual type.</p>
	20	<p>OverlapTransform. This field indicates whether overlap smoothing filter should be performed on I-block boundaries.</p> <p>0 = No overlap smoothing filter. 1 = Overlap smoothing filter performed.</p>
	19	<p>Motion4MV. This field indicates whether current macroblock a progressive P picture uses 4 motion vectors, one for each luminance block.</p> <p>It's only valid for progressive P-picture decoding. Otherwise, it is reserved and MBZ. For example, with MotionForward is 0, this field must also be set to 0.</p> <p>0 = 1MV-mode. 1 = 4MV-mode.</p>
	18	<p>MotionBackward. This field specifies whether the backward motion vector is active for B-picture. This field must be 0 if Motion4MV is 1 (no backward motion vector in 4MV-mode).</p> <p>0 = No backward motion vector. 1 = Use backward motion vector(s).</p>
	17	<p>MotionForward. This field specifies whether the forward motion vector is active for P and B pictures.</p> <p>0 = No forward motion vector. 1 = Use forward motion vector(s).</p>



DWord	Bits	Description
	16	<p>IntraMacroblock. This field specifies if the current macroblock is intra-coded. When set, Coded Block Pattern is ignored and no prediction is performed (i.e., no motion vectors are used).</p> <p>For field motion, this field indicates whether the top field of the macroblock is coded as intra.</p> <p>0 = Non-intra macroblock. 1 = Intra macroblock.</p>
	15:12	<p>LumaIntra8x8Flag – Luma Intra 8x8 Flag</p> <p>This field specifies whether each of the four 8x8 luminance blocks are intra or inter coded when Motion4MV is set to 4MV-Mode.</p> <p>Each bit corresponds to one block. "0" indicates the block is inter coded and '1' indicates the block is intra coded.</p> <p>When Motion4MV is not 4MV-Mode, this field is reserved and MBZ.</p> <p>Bit 15: Y0 Bit 14: Y1 Bit 13: Y2 Bit 12: Y3</p>
	11:6	<p>CBP - Coded Block Pattern</p> <p>This field specifies whether the 8x8 residue blocks in the macroblock are present or not.</p> <p>Each bit corresponds to one block. "0" indicates residue block isn't present, "1" indicates residue block is present.</p> <p>Note: For each block in an intra-coded macroblock or an intra-coded block in a P macroblock in 4MV-Mode, the corresponding CBP must be 1. Subsequently, there must be at least one coefficient (this coefficient might be zero) in the indirect data buffer associated with the block (i.e. residue block must be present).</p> <p>Bit 11: Y0 Bit 10: Y1 Bit 9: Y2 Bit 8: Y3 Bit 7: Cb4 Bit 6: Cr5</p>



DWord	Bits	Description
	5	<p>ChromaIntraFlag - Derived Chroma Intra Flag</p> <p>This field specifies whether the chroma blocks should be treated as intra blocks based on motion vector derivation process in 4MV mode.</p> <p>0 = Chroma blocks are not coded as intra. 1 = Chroma blocks are coded as intra</p>
	4	<p>LastRowFlag – Last Row Flag</p> <p>This field indicates that the current macroblock belongs to the last row of the picture.</p> <p>This field may be used by the kernel to manage pixel output when overlap transform is on.</p> <p>0 = Not in the last row 1 = In the last row</p>
	3	<p>LastMBInRow – This field indicates the last MB in row flag.</p>
	2:0	<p>Reserved. MBZ</p>
+1	32:26	<p>Reserved. MBZ</p>
	25:24	<p>OSEdgeMaskChroma</p> <p>This field contains the overscan edge mask for the Chroma blocks.</p> <p>The left edge masks are hardware and the top edge masks are used by the kernel software.</p> <p>Bit 24: Top edge of block Cb/Cr Bit 25: Left edge of block Cb/Cr</p>
	23:16	<p>OSEdgeMaskLuma</p> <p>This field contains the overscan edge mask for the Luma blocks.</p> <p>The left edge masks are hardware and the top edge masks are used by the kernel software.</p> <p>Bit 16: Top edge of block Y0 Bit 17: Top edge of block Y1 Bit 18: Top edge of block Y2 Bit 19: Top edge of block Y3 Bit 20: Left edge of block Y0 Bit 21: Left edge of block Y1 Bit 22: Left edge of block Y2 Bit 23: Left edge of block Y3</p>



DWord	Bits	Description																														
		<i>Programming Note: In order to create 8 predication bits from each edge mask bit, software may first create a 0, 1 vector by using a shr instruction with a step shift vector like 0, 1, 2, 3 (e.g. using immediate of type :v. Then each 0 or 1 of the LSB can be repeated by an and instruction to create 8 bits to the flag register. Alternatively, this can be achieved with one and instruction using a CURBE constant map of bit 0 and bit 1 mask.</i>																														
	15:8	VertOrigin - Vertical Origin In unit of macroblocks relative to the current picture (frame or field).																														
	7:0	HorzOrigin - Horizontal Origin In unit of macroblocks.																														
+2	31:16	MotionVector[0].Vert																														
	15:0	MotionVector[0].Horz																														
+3	31:0	MotionVector[1]																														
+4	31:0	MotionVector[2]																														
+5	31:0	MotionVector[3]																														
+6	31:0	MotionVectorChroma This field is not valid for a field motion in an interlaced frame picture where 4 MVs for chroma blocks. Notes: This field is derived from MotionVector[3:0] as described in the following section.																														
+7	31:24	<p>Subblock Code for Y3</p> <p>The following subblock coding definition applies to all 6 subblock coding bytes. Bits 7:6 are reserved.</p> <table border="1" style="width: 100%; border-collapse: collapse;"> <thead> <tr> <th colspan="2" style="text-align: center;">Subblock Partitioning (Bits [1:0]) Specify Transform uses for an 8x8 block</th> <th colspan="4" style="text-align: center;">Subblock Present (0 means not present, 1 means present)</th> </tr> <tr> <th style="text-align: center;">Bits [1:0]</th> <th style="text-align: center;">Meaning</th> <th style="text-align: center;">Bit 2</th> <th style="text-align: center;">Bit 3</th> <th style="text-align: center;">Bit 4</th> <th style="text-align: center;">Bit 5</th> </tr> </thead> <tbody> <tr> <td style="text-align: center;">00</td> <td>Single 8x8 block (sb0)</td> <td style="text-align: center;">Sb0</td> <td style="text-align: center;">Don't care</td> <td style="text-align: center;">Don't care</td> <td style="text-align: center;">Don't care</td> </tr> <tr> <td style="text-align: center;">01</td> <td>Two 8x4 subblocks (sb0-1)</td> <td style="text-align: center;">Sb1 (bot)</td> <td style="text-align: center;">Sb0 (top)</td> <td style="text-align: center;">Don't care</td> <td style="text-align: center;">Don't care</td> </tr> <tr> <td style="text-align: center;">10</td> <td>Two 4x8 subblocks</td> <td style="text-align: center;">Sb1 (right)</td> <td style="text-align: center;">Sb0 (left)</td> <td style="text-align: center;">Don't care</td> <td style="text-align: center;">Don't care</td> </tr> </tbody> </table>	Subblock Partitioning (Bits [1:0]) Specify Transform uses for an 8x8 block		Subblock Present (0 means not present, 1 means present)				Bits [1:0]	Meaning	Bit 2	Bit 3	Bit 4	Bit 5	00	Single 8x8 block (sb0)	Sb0	Don't care	Don't care	Don't care	01	Two 8x4 subblocks (sb0-1)	Sb1 (bot)	Sb0 (top)	Don't care	Don't care	10	Two 4x8 subblocks	Sb1 (right)	Sb0 (left)	Don't care	Don't care
Subblock Partitioning (Bits [1:0]) Specify Transform uses for an 8x8 block		Subblock Present (0 means not present, 1 means present)																														
Bits [1:0]	Meaning	Bit 2	Bit 3	Bit 4	Bit 5																											
00	Single 8x8 block (sb0)	Sb0	Don't care	Don't care	Don't care																											
01	Two 8x4 subblocks (sb0-1)	Sb1 (bot)	Sb0 (top)	Don't care	Don't care																											
10	Two 4x8 subblocks	Sb1 (right)	Sb0 (left)	Don't care	Don't care																											



DWord	Bits	Description					
			(sb0-1)				
		11	Four 4x4 subblocks (sb0-3)	Sb3 (lower right)	Sb2 (lower left)	Sb1 (upper right)	Sb0 (upper left)
	23:16	Subblock Code for Y2					
	15:8	Subblock Code for Y1					
	7:0	Subblock Code for Y0					
+8	31:16	Reserved. MBZ					
	15:8	Subblock Code for Cr					
	7:0	Subblock Code for Cb					
+9	31:24	ILDB control data for block Y3					
	23:16	ILDB control data for block Y2					
	15:8	ILDB control data for block Y1					
	7:0	ILDB control data for block Y0					
+10	31:16	Reserved					
	15:8	ILDB control data for Cr block					
	7:0	ILDB control data for Cb block					

Indirect Data Format in VC1-IT Mode

VC1-IT mode only contains IT-COEFF indirect data which is described in *Common Indirect IT-COEFF Data Structure*.

Inline Data Description in MPEG2-IT Mode

The content in this command is similar to that in the MEDIA_OBJECT command in IS mode described in the Media Chapter.

Each MFD_IT_OBJECT command corresponds to the processing of one macroblock. Macroblock parameters are passed in as inline data and the non-zero DCT coefficient data for the macroblock is passed in as indirect data.



Inline Data Description in MPEG2-IT Mode depicts the inline data format. Inline data starts at dword 7 of MFD_IT_OBJECT command. There are 7 dwords total.

Inline data in MPEG2-IT Mode

DWord	Bit	Description																				
+0	31:28	<p>Motion Vertical Field Select. A bit-wise representation of a long [2][2] array as defined in §6.3.17.2 of the <i>ISO/IEC 13818-2</i> (see also §7.6.4).</p> <table border="1"> <thead> <tr> <th>Bit</th> <th>MVector[r]</th> <th>MVector[s]</th> <th>MotionVerticalFieldSelect Index</th> </tr> </thead> <tbody> <tr> <td>28</td> <td>0</td> <td>0</td> <td>0</td> </tr> <tr> <td>29</td> <td>0</td> <td>1</td> <td>1</td> </tr> <tr> <td>30</td> <td>1</td> <td>0</td> <td>2</td> </tr> <tr> <td>31</td> <td>1</td> <td>1</td> <td>3</td> </tr> </tbody> </table> <p>Format = MC_MotionVerticalFieldSelect.</p> <p>0 = The prediction is taken from the <u>top</u> reference field.</p> <p>1 = The prediction is taken from the <u>bottom</u> reference field.</p>	Bit	MVector[r]	MVector[s]	MotionVerticalFieldSelect Index	28	0	0	0	29	0	1	1	30	1	0	2	31	1	1	3
Bit	MVector[r]	MVector[s]	MotionVerticalFieldSelect Index																			
28	0	0	0																			
29	0	1	1																			
30	1	0	2																			
31	1	1	3																			
	27	Reserved (was Second Field)																				
	26	Reserved. (HWMC mode)																				
	25:24	<p>Motion Type. When combined with the destination picture type (field or frame) this Motion Type field indicates the type of motion to be applied to the macroblock. See <i>ISO/IEC 13818-2</i> §6.3.17.1, Tables 6-17, 6-18. In particular, the device supports dual-prime motion prediction (11) in both frame and field picture type.</p> <p>Format = MC_MotionType</p> <table border="1"> <thead> <tr> <th rowspan="2">Value</th> <th>Destination = Frame</th> <th>Destination = Field</th> </tr> <tr> <th>Picture_Structure = 11</th> <th>Picture_Structure != 11</th> </tr> </thead> <tbody> <tr> <td>'00'</td> <td>Reserved</td> <td>Reserved</td> </tr> <tr> <td>'01'</td> <td>Field</td> <td>Field</td> </tr> <tr> <td>'10'</td> <td>Frame</td> <td>16x8</td> </tr> <tr> <td>'11'</td> <td>Dual-Prime</td> <td>Dual-Prime</td> </tr> </tbody> </table>	Value	Destination = Frame	Destination = Field	Picture_Structure = 11	Picture_Structure != 11	'00'	Reserved	Reserved	'01'	Field	Field	'10'	Frame	16x8	'11'	Dual-Prime	Dual-Prime			
Value	Destination = Frame	Destination = Field																				
	Picture_Structure = 11	Picture_Structure != 11																				
'00'	Reserved	Reserved																				
'01'	Field	Field																				
'10'	Frame	16x8																				
'11'	Dual-Prime	Dual-Prime																				
	23:22	Reserved. (Scan method)																				
	21	<p>DCT Type. This field specifies the DCT type of the current macroblock. The kernel should ignore this field when processing Cb/Cr data. See <i>ISO/IEC 13818-2</i> §6.3.17.1. This field is zero if Coded Block Pattern is also zero (no coded blocks present).</p> <p>0 = MC_FRAME_DCT (Macroblock is frame DCT coded).</p> <p>1 = MC_FIELD_DCT (Macroblock is field DCT coded).</p>																				
	20	Reserved (was Overlap Transform - H261 Loop Filter).																				



DWord	Bit	Description
	19	Reserved (was 4MV Mode - H263)
	18	<p>Macroblock Motion Backward. This field specifies if the backward motion vector is active. See <i>ISO/IEC 13818-2</i> Tables B-2 through B-4.</p> <p>0 = No backward motion vector. 1 = Use backward motion vector(s).</p>
	17	<p>Macroblock Motion Forward. This field specifies if the forward motion vector is active. See <i>ISO/IEC 13818-2</i> Tables B-2 through B-4.</p> <p>0 = No forward motion vector. 1 = Use forward motion vector(s).</p>
	16	<p>Macroblock Intra Type. This field specifies if the current macroblock is intra-coded. When set, Coded Block Pattern is ignored and no prediction is performed (i.e., no motion vectors are used). See <i>ISO/IEC 13818-2</i> Tables B-2 through B-4.</p> <p>0 = Non-intra macroblock. 1 = Intra macroblock.</p>
	15:12	Reserved : MBZ
	11:6	<p>Coded Block Pattern. This field specifies whether blocks are present or not.</p> <p>Format = 6-bit mask.</p> <p>Bit 11: Y0 Bit 10: Y1 Bit 9: Y2 Bit 8: Y3 Bit 7: Cb4 Bit 6: Cr5</p>
	5:4	Reserved. (Quantization Scale Code)
	3	LastMBInRow – This field indicates the last MB in each row.
	2:0	Reserved: MBZ
+1	31:16	Reserved : MBZ
	15:8	<p>VertOrigin - Vertical Origin In unit of macroblocks relative to the current picture (frame or field).</p>
	7:0	<p>HorzOrigin - Horizontal Origin In unit of macroblocks.</p>



DWord	Bit	Description
+2	31:16	Motion Vectors – Field 0, Forward, Vertical Component. Each vector component is a 16-bit two's-complement value. The vector is relative to the current macroblock location. According to ISO/IEC 13818-2 Table 8, the valid range of each vector component is [-2048, +2047.5], implying a format of s11.1. However, it should be noted that motion vector values are sign extended to 16 bits.
	15:0	Motion Vectors – Field 0, Forward, Horizontal Component
+3	31:16	Motion Vectors – Field 0, Backward, Vertical Component
	15:0	Motion Vectors – Field 0, Backward, Horizontal Component
+4	31:16	Motion Vectors – Field 1, Forward, Vertical Component
	15:0	Motion Vectors – Field 1, Forward, Horizontal Component
+5	31:16	Motion Vectors – Field 1, Backward, Vertical Component
	15:0	Motion Vectors – Field 1, Backward, Horizontal Component

Indirect Data Format in MPEG2-IT Mode

MPEG2-IT mode only contains IT-COEFF indirect data which is described in Section *Common Indirect IT-COEFF Data Structure*.



MFX Deblocking Commands

Following are MFX Deblocking Commands:

MFX_DBK_OBJECT DevHSW:GT3:A, DevHSW:GT3:B, DevHSW:GT2:B

MFX Error Handling

This topic is currently under development.



Encoder StreamOut Mode Data Structure Definition

When StreamOut is enabled, per MB (and/or per Slice, per Picture) intermediated coding data (e.g. bit allocated for each MB, etc.) are sent to the memory in a fixed record format (and of fixed size) from the PAK. The per-MB records must be written in a strict raster order and with no gap (i.e. every MB regardless of its mb_type and slice type, must have an entry in the StreamOut buffer). Therefore, the consumer of the StreamOut data can offset into the StreamOut Buffer (**StreamOut Data Destination Base Address**) using individual MB addresses.

Adding per macroblock stream out for PAK is for the following purposes:

- Immediate multi-pass PAK (without host or EU intervention)
 - 3200-bit conformance
 - Re-quantization
- Providing information for host for offline processing
- Providing information for updated QP's

The description for the fixed format PAK streamout record :

Streamout Pointer: Use the existing streamout pointer and enabler

Per Macroblock Information (a fixed size structure)

DWord	Bit	Description
0	31:24	MbQpY - Actual QPY used by the macroblock.
	23:16	[IVB+] MbClock16 – MB compute clocks in 16-clock unit.
	15:8	Reserved : MBZ
	7:4	Reserved : MBZ (future conformance flags)
	3	Reserved
	2	MbRcFlag : MB level Rate control flag(pass through) The same value as RateControlCounterEnable of MFX_AVC_SLICE_STATE Command
	1	MbInterConfFlag : MB level InterMB conformance flag to trigger mutli-pass 1- if total Bit Count of an inter macroblock is more than Inter Conformance Max size limit in the MFX_AVC_IMG_STATE Command
	0	MbIntraConfFlag : MB level IntraMB conformance flag to trigger mutli-pass 1- if total Bit Count of an intra macroblock is more than Intra Conformance Max size



DWord	Bit	Description
		limit in the MFX_AVC_IMG_STATE Command
1	31:29	Reserved
	28:16	MbBits : Total Bit Count for the macroblock
	15:12	Reserved
	12:0	MbHdrBits : Header Bit count (bit count due to Pre-coefficient data) for the macroblock
2	31:27	Reserved
	26:0	Cbp : Coded Block Pattern of sub-blocks
3	31:30	Reserved
	29	IntraMBFlag
	28:24	MbType5Bits
	23:17	Reserved
	16	ClampFlag : Coefficient clamping flag for RC (Status) 1 - Indicates if clamping of any coefficient is done on the macroblock for Rate Control
	15:0	Reserved (future QRC stat output)



PAK Multi-Pass

Multi-Pass PAK Usages:

- Intra MB 3200-bit conformance
- Inter MB Re-quantization
- Frame level Re-quantization

How to Enable Multi-Pass PAK?

- Using the existing conditional batch buffer execution capability to skip/execute the second pass
 - How to dynamically change the condition?
 - Defined one error condition register with a mask. Do HW status page update at the end of the first pass. 0 means all OK, non-zero means there is an error condition, requiring second pass. Mask is used by the host to control what kind of multi-pass is intended.
 - For example, one error bit is 3200-bit conformance violation. Another error bit is the total bit count exceeds (too much or too little) the target range (need to define the target range in the state).
 - **The logic perfectly fits in the conditional batch buffer control logic that VCS has today in GT. There is no additional logic need to be added in VCS to support media functionality. (Batch Buffer Skip: This field only takes effect if Compare Semaphore is set and the value at Semaphore Address is NOT greater than the Semaphore Data Dword).**
- Adding a picture level state command to enable and control the behavior of the second pass PAK
 - How to control the re-PAK? Added 3 conformance flags (error registers) in the per-MB streamout. Then the error control is based on the error register and the mask defined in picture level states. There are 8 register flags defined out of which only the 3200-bit case has usage model defined for today. The rest are left for future usage.

Issues and Limitations:

- There is no programmable engine in MFX for flexible control: Therefore, whatever we have defined must consider flexibility

Following 2 MI packets are used inside VCS without any change to support Multipass-PAK behaviour.

- MI_Conditional_Batch_Buffer_End
- Memory Interface Registers

Driver Usage

Driver places Image states in one batch buffer and all slice level and macroblock level states into another batch buffer and link 2 batch buffers. Also replicate Image states with multipass changes in another batch buffer link them to slice/macroblock batch buffer. In this way, only Image states are replicated but not the slice/macroblock states. The image states includes all buffers defined at image(indirectMV, original pixel buffer, etc). Following changes are needed in the Multipass Image State,

- **Reset- Stream-Out Enable(disable stream out in the second pass)**
- **Set- MacroblockStatEnable (enable reading of macroblock status buffer)**
- **Reset- 3200-bit conformance (do not report 3200-bit conformance)**

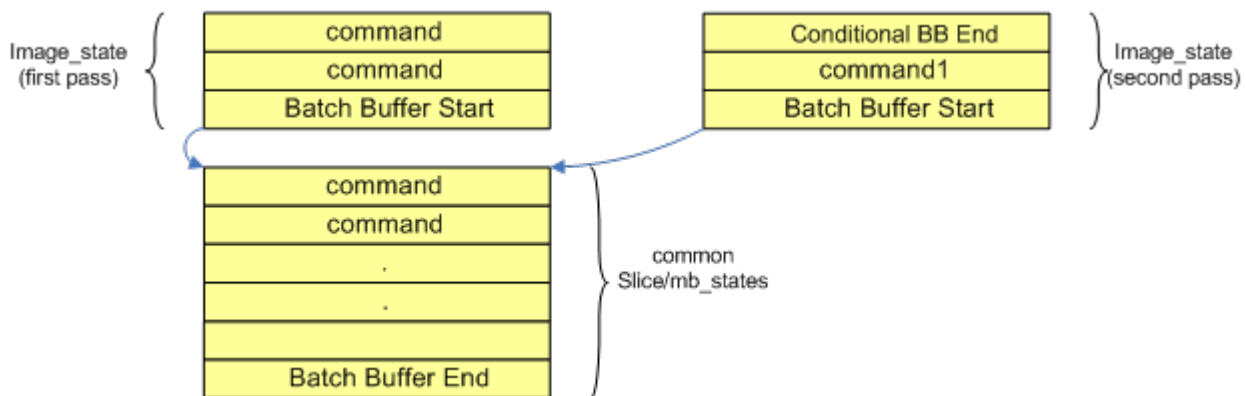

Define Conditional Batch Buffer End for CS/VCSVINunit



Programming Reference

Monochrome Picture Processing

Monochrome picture is specified using the Surface State with Surface Format of 12. Therefore, MFX hardware, in either decode or encode mode, does not generate any read or write traffic for U/V components. The motivation for this bandwidth optimization is that monochrome video coding might be used for wireless display.

For Encoder:

1. No read in UV original components
2. Processing UV component - no
3. Reconstructed UV component reference picture - no
4. Filter UV component - no

For Decoder:

1. VLD mode: There is no color component coming out of the decoding pipeline in Monochrome mode and so no processing and not writing output.
2. IT mode: There is no color component in the coefficient buffer, and so no processing and not writing output.



Context Switch

There is no pre-emption for the BCS pipeline; hence every command buffer is required to contain all the states setup (preamble). Specifically, CPU can not interrupt the BCS-BSD pipe, to stop the operation in the middle of decoding a bitstream data.

Switch of contexts can only be performed at picture boundary.

No state needs to be saved.



Pipeline Flush

Implicit flush for AVC and VC1 is performed at the end of Slice : for MPEG2 is done when a new image/picture command is issued. Because MPEG2 a slice can be one MB, no point to flush. MPEG2 will snoop the next command if it is an img_state command.

Explicit flush MI (1 bit to do media pipeline vs Gx pipeline) flush and cache flush (switch reference frame)
– MI flush has bit to do cache flush. MI flush is for driver synchronization.



MMIO Interface

A set of registers are defined and accessible through MMIO interface to serve multiple purposes:

- Use for system configuration
- For accessing Performance counters

Register Name	Description	Register Type	Address Offset	Dec/Enc
MFD ERROR Status	MFD ERROR STATUS_VLD ERROR flags and counter	RO	12400	Dec
Reserved	MBZ		12404~1241C	
MFD picture-level parameter	VC1 picture level parameters	R/W	12420	Dec
Reserved	MBZ		12434	
MFx PIPELINE_STATUS_FLAGS	MFx PIPELINE STATUS Flags_MFx pipeline mode flags	RO	12438	Dec
MFx_Error_Injection_Parameter	Control HW error injector	WO	12454	Dec
Reserved			12458~1245C	
MFx Frame Performance count	Number of clocks spent decoding/encoding a frame	RO	12460	Dec/Enc
MFx Slice Performance count	Number of clocks spent decoding/encoding a slice	RO	12464	Dec/Enc
MFx Frame Macroblock count	Number of MBs decoded/encoded per frame	RO	12468	Dec/Enc
MFD Frame BITSTREAM SE/BIN count	Number of bin/SE decoded per frame	RO	1246C	Dec
MFx Memory Latency count1	Reference picture read latency -min and max	RO	12470	Dec/Enc
MFx Memory Latency count2	Reference picture read latency - Accumulative (used for compute AVE latency)	RO	12474	Dec/Enc
MFx Memory Latency count3	row-store/bit-stream memory read latency -min and max	RO	12478	Dec/Enc
MFx Memory Latency count4	row-store/bit-stream memory read latency - accumulative (used to compute AVE latency)	RO	1247C	Dec/End
MFx Frame row-stored/bit-stream read Count	# of row-store memory requests sent	RO	12480	Dec/End
MFx Motion Comp read Count	total number of CL memory accesses per frame	RO	12484	Dec/End
MFx Motion Comp MISS Count	total number of CL HITs per frame	RO	12488	Dec/End
Reserved			1248C~1249C	
MFC_BITSTREAM_BYTECOUNT_FRAME	Total Bitstream Output Byte Count register per Frame	RO	124A0	Enc



Register Name	Description	Register Type	Address Offset	Dec/Enc
MFC_BITSTREAM_SE_BITCOUNT_FRAME	Bitstream Output total Byte Count for syntax elements (total bytes of MB data from SEC per frame)	RO	124A4	Enc
MFC_AVC_CABAC_BIN_COUNT_FRAME	Bitstream Output total bin count per frame	RO	124A8	Enc
MFC_AVC_CABAC_INSERTION_COUNT	Bitstream Output CABAC Insertion Count Register	RO	124AC	Enc
MFC_AVC_MINSIZE_PADDING_COUNT	Bitstream Output Minimal Size Padding Count Register	RO	124B0	Enc
MFC_IMAGE_STATUS_MASK	image status(flags).	R/W	124B4	Enc
MFC_IMAGE_STATUS_CONTROL	suggested data for next frame in multi-pass.	RO	124B8	Enc
MFC_QP_STATUS_COUNT	Overall adjusted delta QP via multi-pass, Sum of QPY for all macroblocks of the frame	RO	124BC	Enc
			124C0~124CC	Enc
MFC_BITSTREAM_BYTECOUNT_SLICE	Bitstream Output Byte Count Register per Slice	RO	124D0	Enc
MFC_BITSTREAM_SE_BITCOUNT_SLICE	Bitstream Output Bit Count for the last Syntax Element Register	RO	124D4	Enc
PAK_REPORT_WARNING	MPC Warning Register	RO	124E4	Enc
PAK_REPORT_ERROR	MPC Error Register	RO	124E8	Enc
PAK_REPORT_RUNNING	PAK_REPORT_RUNNING status register	RO	124EC	Enc
Reserved			124F0~124FC	Enc



Decoder Registers

Following are Decoder Registers:

MFD_ERROR_STATUS - MFD Error Status

AVC_CAVLC

AVC_CABAC

VC1

MPEG2

JPEG

MFD_PICTURE_PARAM - MFD Picture Parameter

MXF_STATUS_FLAGS - MFX Pipeline Status Flags

MXF_FRAME_PERFORMANCE_CT - MFX Frame Performance Count

MXF_SLICE_PERFORM_CT - MFX Slice Performance Count

MXF_MB_COUNT - MFX Frame Macroblock Count

MXF_SE-BIN_CT - MFX Frame BitStream SE/BIN Count

MXF_LAT_CT1 - MFX Memory Latency Count1

MXF_LAT_CT2 - MFX Memory Latency Count2

MXF_LAT_CT3 - MFX Memory Latency Count3

MXF_LAT_CT4 - MFX Memory Latency Count4

MXF_SE-BIN_CT - MFX Frame BitStream SE/BIN Count

MXF_READ_CT - MFX Frame Motion Comp Read Count

MXF_MISS_CT - MFX Frame Motion Comp Miss Count



Encoder Registers

Following are the Encoder Registers:

MFC_VIN_AVD_ERROR_CNTR - MFC_AVC Bitstream Decoding Front-End Parsing Logic Error Counter

MFC_BITSTREAM_BYTECOUNT_FRAME - Reported Bitstream Output Byte Count per Frame Register

MFC_BITSTREAM_SE_BITCOUNT_FRAME - Reported Bitstream Output Bit Count for Syntax Elements Only Register

MFC_AVC_CABAC_BIN_COUNT_FRAME - Reported Bitstream Output CABAC Bin Count Register

AVC_CABAC_INSERTION_COUNT - MFC_AVC_CABAC_INSERTION_COUNT

MFC_AVC_MINSIZE_PADDING_COUNT - Bitstream Output Minimal Size Padding Count Report Register

MFC_IMAGE_STATUS_MASK - MFC Image Status Mask

MFC_IMAGE_STATUS_CONTROL - MFC Image Status Control

MFC_QUP_CT - MFC QP Status Count

MFC_BITSTREAM_BYTECOUNT_SLICE - Bitstream Output Byte Count Per Slice Report Register

MFC_BITSTREAM_SE_BITCOUNT_SLICE - Bitstream Output Bit Count for the last Syntax Element Report Register



Row Store Sizes and Allocations

	AVC	VC1	MPEG2	JPEG	IT	ENC	SEC ENC
vin_vmx_pixcoefind_addr[31:6]	Bitstream	Bitstream	Bitstream	Bitstream	VDS COEF	Orig Pix	BSP data
vin_vmx_mvbsdrs_addr[31:6]	VAD BSD		VMD RS		VDS MV	MPC MV	
vin_vmx_mpcildbmpr_addr[31:6]	VAM MPR				VDS ILDB	MPC RS	
vin_vmx_dmv*_addr[31:6]	VAM DMV	VCP DMV					
vin_vmx_bp_addr [31:0]		VCP BP					

MPEG2 VLD Decoding Mode :

use BSD Row Store only, and

MPEG2 IT Decoding Mode :

MPEG2 IT mode does not need row-store

JPEG VLD Decoding Mode : no row store is needed